

Extrablame®

Riscaldamento a Pellet



UK

PELLET STOVES USER MANUAL

MADE IN ITALY
design & production

LUCIA





ATTENTION



**SURFACES CAN BECOME VERY HOT!
ALWAYS USE PROTECTIVE GLOVES!**

During combustion, thermal energy is released that significantly increases the heat of surfaces, doors, handles, controls, glass, exhaust pipes, and even the front of the appliance. Avoid contact with those elements if not wearing protective clothing (protective gloves included). Make sure children are aware of the danger and keep them away from the stove during operation.

| | |
|---|-----------|
| ENGLISH | 5 |
| WARNINGS | 5 |
| SAFETY | 5 |
| ROUTINE MAINTENANCE | 7 |
| INSTALLATION | 8 |
| PREPARATIONS FOR MAINTENANCE | 8 |
| DETAILS LUCIA | 10 |
| POSITIONING THE STOVE | 11 |
| NOTES FOR CORRECT OPERATION | 11 |
| FUSE | 11 |
| PELLETS AND LOADING | 12 |
| PELLET HOPPER - PRESSURISED CLOSURE | 12 |
| REMOTE CONTROL | 13 |
| REMOTE CONTROL ICONS | 14 |
| INSERTING THE BATTERIES | 14 |
| ADVICE AND PRECAUTIONS FOR THE USE OF THE REMOTE CONTROL | 14 |
| TOUCH SCREEN DISPLAY | 15 |
| DISPLAY OPENING | 15 |
| DISPLAY CLOSING | 15 |
| CONTROL PANEL | 16 |
| ICON KEY | 16 |
| MAIN MENU | 17 |
| GENERAL WARNINGS | 17 |
| SETTINGS FOR FIRST USE | 18 |
| DATE-TIME | 18 |
| LANGUAGE | 18 |
| DEGREES | 18 |
| OPERATION AND LOGIC | 19 |
| FRONT AIR | 20 |
| EASY SETUP | 20 |
| CHRONO | 21 |
| ENABLING/DISABLING THE CHRONO | 21 |
| SETTINGS | 23 |
| DISPLAY | 23 |
| STAND - BY | 23 |
| OPERATION WITH ADDITIONAL THERMOSTAT (OPTIONAL) | 23 |
| ADDITIONAL THERMOSTAT | 24 |
| INSTALLATION OF ADDITIONAL THERMOSTAT | 24 |
| DELTA T | 24 |
| FIRST LOAD | 24 |
| WI-FI | 25 |
| RESET | 25 |
| CLEANING AND MAINTENANCE | 26 |
| MAINTENANCE | 26 |
| PERIODICAL CLEANING BY THE USER | 26 |
| ROUTINE MAINTENANCE PERFORMED BY QUALIFIED TECHNICIANS | 28 |
| PUTTING OUT OF SERVICE (END OF SEASON) | 28 |
| DISPLAYS | 31 |
| ALARMS | 31 |
| GUARANTEE TERMS | 32 |
| DISPOSAL | 33 |

| | |
|--|---|
| <p>ATTENZIONE TASSATIVO PRIMA DI MOVIMENTARE LA STUFA TOGLIERE LE MAIOLICHE INDICATE PER EVITARE DANNI.</p> | <p>ATENÇÃO - OBRIGATÓRIO ANTES DE MOVIMENTAR A SALAMANDRA, RE- TIRAR AS CERÂMICAS INDICADAS PARA EVITAR DANOS.</p> |
| <p>ATTENTION - COMPULSORY BEFORE MOVING THE STOVE, KINDLY TAKE THE CERAMICS OFF IN ORDER TO AVOID ANY DAMAGES</p> | <p>TÄHELEPANU! ENNE AHJU LIIGUTAMIST EEMALDAGE SELLELT NÄIDATUD KERAAMILISED OSAD, ET VÄLTIDA KAHJUSTUSI.</p> |
| <p>ATTENTION - OBLIGATOIRE AVANT DE BOUGER LE POÊLE, FAIRE ATTENTION À LEVER LES CÉRAMIQUES INDIQUÉES POUR ÉVITER DES DÉGÂTS</p> | <p>OBVEZNA POZORNOST PRIJE POMICANJA PEĆI, UKLONITE OZNAČENE PLOČICE KAKO BISTE IZBJEGLI OŠTEĆENJA.</p> |
| <p>VORSICHT - OBLIGATORISCH BEVOR SIE DEN OFEN BEWEGEN, BITTE UNBE- DINGT DIE BEZEICHNETE KERAMIK KACHELN ENTFERNEN UM SCHÄDEN ZU VERMEIDEN</p> | <p>POZOR OBVEZNO PRED PREMIKANJEM PEČI ODSTRANITE OZNAČENE MAJOLIKE, DA PREPREČITE POŠKODOVANJE.</p> |
| <p>ATENCIÓN - PERENTORIO ANTES DE MOVER LA ESTUFA SACAR LAS MAYÓLICAS INDICADAS PARA EVITAR DAÑOS.</p> | <p>ADVARSEL - OBLIGATORISK FØR DU FLYTTER OVNEN, BØR DU TAGE KERAMIKFLISERNE AF FOR AT UNDGÅ SKADER.</p> |

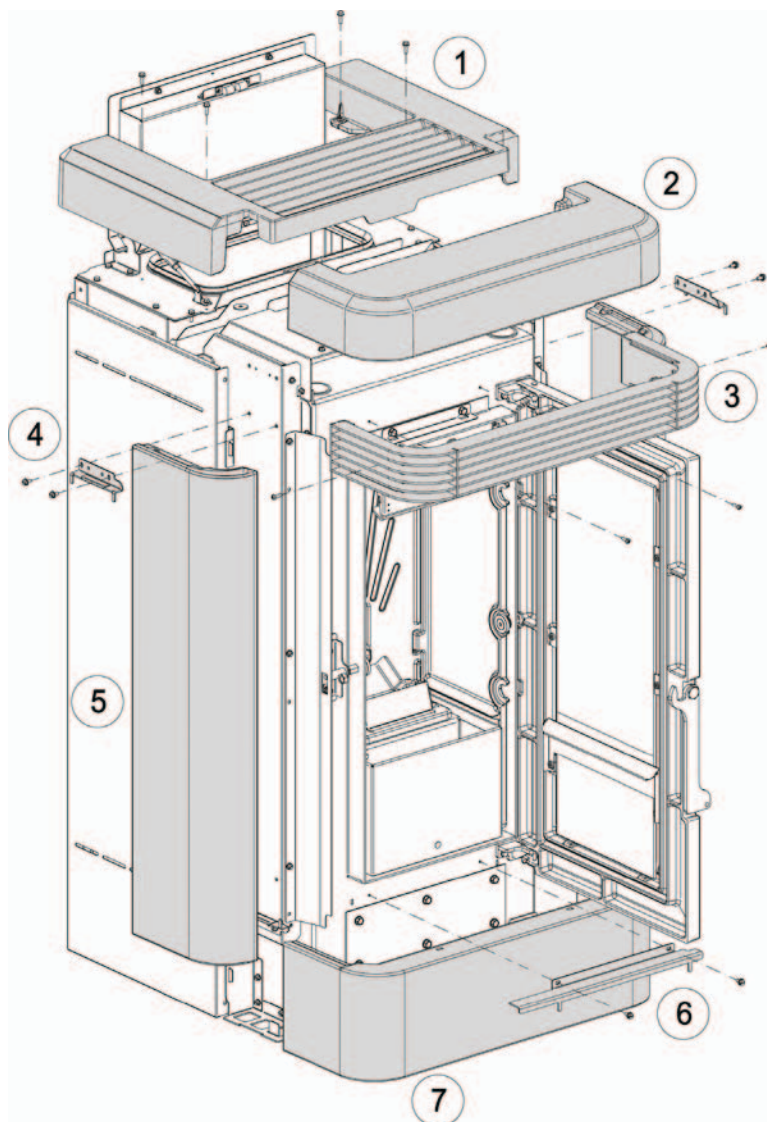

We thank you for having chosen our company; our product is a great heating solution developed from the most advanced technology with top quality machining and modern design, aimed at making you enjoy the fantastic sensation that the heat of a flame gives, in complete safety.

WARNINGS

This instructions manual is an integral part of the product: make sure that it always accompanies the appliance, even if transferred to another owner or user, or if transferred to another place. If it is damaged or lost, request another copy from the area technician. This product is intended for the use for which it has been expressly designed. The manufacturer is exempt from any liability, contractual and extracontractual, for injury/damage caused to persons/animals and objects, due to installation, adjustment and maintenance errors and improper use.

Installation must be performed by qualified staff, which assumes complete responsibility for the definitive installation and consequent good functioning of the product installed. One must also bear in mind all laws and national, regional, provincial and town council Standards present in the country in which the appliance has been installed, as well as the instructions contained in this manual.

The Manufacturer cannot be held responsible for the failure to comply with such precautions.

After removing the packaging, ensure that the content is intact and complete. Otherwise, contact the dealer where the appliance was purchased. All electric components that make up the product must be replaced with original spare parts exclusively by an authorised after-sales centre, thus guaranteeing correct functioning.

SAFETY

- ◆ **THE APPLIANCE MAY BE USED BY CHILDREN 8 YEARS OF AGE OR OLDER AND INDIVIDUALS WITH REDUCED PHYSICAL, SENSORY, OR MENTAL CAPACITIES OR WITHOUT EXPERIENCE OR THE NECESSARY KNOWLEDGE, PROVIDED THAT THEY ARE SUPERVISED OR HAVE RECEIVED INSTRUCTIONS ON SAFE USE OF THE APPLIANCE AND THAT THEY UNDERSTAND THE INHERENT DANGERS.**
- ◆ **THE GENERATOR MUST NOT BE USED BY PERSONS (INCLUDING**

CHILDREN) WITH REDUCED PHYSICAL, SENSORY AND MENTAL CAPACITIES OR WHO ARE UNSKILLED PERSONS, UNLESS THEY ARE SUPERVISED AND TRAINED REGARDING USE OF THE APPLIANCE BY A PERSON RESPONSIBLE FOR THEIR SAFETY.

- ◆ THE CLEANING AND MAINTENANCE REQUIRED BY THE USER MUST NOT BE PERFORMED BY CHILDREN WITHOUT SUPERVISION.
- ◆ CHILDREN MUST BE CHECKED TO ENSURE THAT THEY DO NOT PLAY WITH THE APPLIANCE.
- ◆ DO NOT TOUCH THE GENERATOR WHEN YOU ARE BAREFOOT OR WHEN PARTS OF THE BODY ARE WET OR DAMP.
- ◆ THE SAFETY AND ADJUSTMENT DEVICES MUST NOT BE MODIFIED WITHOUT THE AUTHORISATION OR INDICATIONS OF THE MANUFACTURER.
- ◆ DO NOT PULL, REMOVE, TWIST THE ELECTRICAL CABLES COMING OUT OF THE PRODUCT EVEN IF IT IS DISCONNECTED FROM THE MAINS.
- ◆ IT IS ADVISED TO POSITION THE POWER SUPPLY CABLE SO THAT IT DOES NOT COME INTO CONTACT WITH HOT PARTS OF THE APPLIANCE.
- ◆ THE POWER SUPPLY PLUG MUST BE ACCESSIBLE AFTER INSTALLATION.
- ◆ DO NOT CLOSE OR REDUCE THE DIMENSIONS OF THE AIRING VENTS IN THE PLACE OF INSTALLATION. THE AIRING VENTS ARE ESSENTIAL FOR CORRECT COMBUSTION.
- ◆ DO NOT LEAVE THE PACKAGING ELEMENTS WITHIN REACH OF CHILDREN OR UNASSISTED DISABLED PERSONS.
- ◆ THE HEARTH DOOR MUST ALWAYS BE CLOSED DURING NORMAL FUNCTIONING OF THE PRODUCT.
- ◆ WHEN THE APPLIANCE IS FUNCTIONING AND HOT TO THE TOUCH, ESPECIALLY ALL EXTERNAL SURFACES, ATTENTION MUST BE PAID
- ◆ CHECK FOR THE PRESENCE OF ANY OBSTRUCTIONS BEFORE SWITCHING THE APPLIANCE ON FOLLOWING A PROLONGED PERIOD OF INACTIVITY.
- ◆ THE GENERATOR HAS BEEN DESIGNED TO FUNCTION IN ANY CLIMATIC CONDITION. IN PARTICULARLY ADVERSE CONDITIONS (STRONG WIND, FREEZING) SAFETY SYSTEMS MAY INTERVENE THAT SWITCH THE GENERATOR OFF. IF THIS OCCURS, CONTACT THE TECHNICAL AFTER-SALES SERVICE AND ALWAYS DISABLE THE SAFETY

SYSTEMS.

- ◆ IN THE EVENT THE FLUE CATCHES FIRE, USE SUITABLE SYSTEMS FOR SUFFOCATING THE FLAMES OR REQUEST HELP FROM THE FIRE BRIGADE.
- ◆ THIS APPLIANCE MUST NOT BE USED TO BURN WASTE
- ◆ DO NOT USE ANY FLAMMABLE LIQUIDS FOR IGNITION
- ◆ DURING THE FILLING PHASE DO NOT PUT THE BAG OF PELLETS TO INTO CONTACT WITH THE PRODUCT
- ◆ THE MAJOLICAS ARE TOP QUALITY ARTISAN PRODUCTS AND AS SUCH CAN HAVE MICRO-DOTS, CRACKLES AND CHROMATIC IMPERFECTIONS. THESE FEATURES HIGHLIGHT THEIR VALUABLE NATURE. DUE TO THEIR DIFFERENT DILATION COEFFICIENT, THEY PRODUCE CRACKLING, WHICH DEMONSTRATE THEIR EFFECTIVE AUTHENTICITY. TO CLEAN THE MAJOLICAS, IT IS RECOMMENDED TO USE A SOFT, DRY CLOTH. IF A DETERGENT OR LIQUID IS USED, THE LATTER COULD PENETRATE INSIDE THE CRACKLES, HIGHLIGHTING THEM.
- ◆ SINCE THE PRODUCT CAN TURN ON AUTOMATICALLY THANKS TO THE TIMER, OR REMOTELY USING THE DEDICATED APPLICATIONS, IT IS STRICTLY FORBIDDEN TO LEAVE ANY COMBUSTIBLE OBJECT WITHIN THE SAFETY DISTANCES INDICATED ON THE TECHNICAL DATA PLATE.
- ◆ INTERNAL COMBUSTION CHAMBER PARTS CAN BE SUBJECT TO EXTETICAL WARN, IT DOESN'T AFFECT THE FUNCTIONALITY

ROUTINE MAINTENANCE

Based on Decree 22 January 2008 n°37 art.2, routine maintenance means interventions aimed at reducing degradation due to normal use, as well as dealing with accidental events entailing the need of first interventions, which however do not modify the structure of the system upon which one is intervening or its intended use according to the requirements laid down by the technical standards in force and by the manufacturer's use and maintenance manual.

INSTALLATION

GENERAL

The flue gas exhaust and hydraulic connections must be carried out by qualified personnel who must issue installation conformity documentation compliant with national standards.

The installer must provide the owner or person acting for him, according to the legislation in force, with the declaration of conformity, supplied with:

- 1) the use and maintenance manual of the appliance and of the system components (such as for example, the smoke ducts, chimney, etc.);
- 2) photocopy or photograph of the chimney plaque;
- 3) system booklet (where applicable).

The installer must ask to be issued with a receipt stating that the documentation has been provided, and must keep it with a copy of the technical documentation relating to the installation.

For installation in a condominium, prior approval from the condominium's administrator must be requested.

Where required, check the exhaust gas emissions after installation. Should a sampling point be installed, it must be airtight.

COMPATIBILITY

Do not install in rooms with a fire hazard. It is also forbidden to install it in living areas with the following characteristics:

1. where there are liquid fuel appliances with continuous or discontinuous operation that draw the combustion air into the room in which they are installed.
2. where there are type B gas appliances intended for heating, with or without domestic hot water production and in adjacent and communicating rooms.
3. where the depression measured in situ between the external and internal environment is greater than 4 Pa.

N.B.: Watertight appliances can also be installed in the cases indicated in points 1, 2 and 3 of this paragraph.

INSTALLATIONS IN BATHROOMS, BEDROOMS AND STUDIO FLATS

Installation in bathrooms, bedrooms and studio flats is only allowed for sealed or closed hearth appliances with ducted combustion air taken from the outside.

POSITIONING AND SAFETY DISTANCES

The support surfaces and/or points must have a suitable capacity to bear the overall weight of the appliance, accessories and coverings. If the floor is made of a combustible material, we recommend using a non-combustible material to protect the front part from any burnt material which might fall during routine cleaning operations. The generator must be level to function properly. The side walls, the rear walls and the floor support surface should be made of non-combustible material.

MINIMUM DISTANCES (PELLET STOVES)

Installation next to flammable or heat-sensitive materials is permitted **only if the special safety distances specified on the label at the beginning of the manual (pag.2) are observed**. If the materials are not flammable, you must keep a side and rear distance of at least 100 mm (without the inserts). For products equipped with rear spacers, wall-mounting installation is permitted exclusively for the rear side.

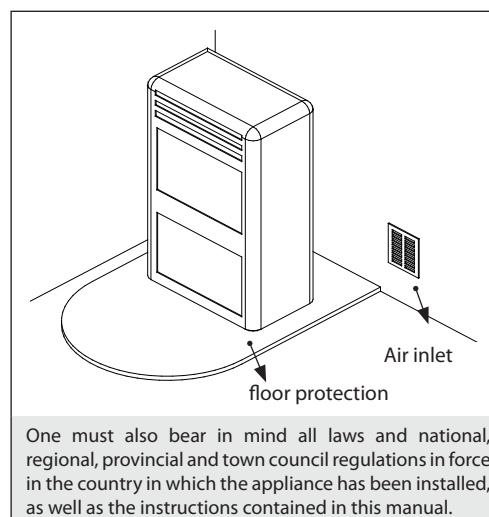

PREPARATIONS FOR MAINTENANCE

To carry out extraordinary maintenance operations on the product, it may be necessary to move it away from the adjacent walls. This must be done by a technician authorised to disconnect the combustion product evacuation ducts and then reconnect them. For heaters connected to the hydraulic system, the connection between the system itself and the product must be made in such a way that, when an authorised technician is about to carry out extraordinary maintenance operations, it is possible to move the heater at least 1 metre away from the adjacent walls.

INSTALLING INSERTS

When installing inserts, access must be prevented to the internal parts of the appliance and it must not be possible to access live parts during extraction operations.

Any wiring, for example the power cable or room probe, must be positioned so as not to be damaged during movement of the insert and must not come into contact with hot parts. If a cavity made of combustible material is installed, we recommend taking all the safety precautions indicated by the installation standards.

VENTILATION AND AERATION OF INSTALLATION ROOMS

In case of non-airtight heater and/or installation, the ventilation must respect the minimum area indicated below (considering the highest value among those provided):

| Appliance categories | Reference standard | Percentage of the net opening section with respect to the appliance fumes outlet section | Minimum net opening value of the ventilation duct |
|----------------------|--------------------|--|---|
| Pellet stoves | UNI EN 14785 | - | 80 cm ² |
| Boilers | UNI EN 303-5 | 50% | 100 cm ² |

Under any condition, including in the presence of extractor hoods and/or of controlled forced ventilation systems, the pressure difference between the generator installation rooms and the outside must always be equal to or less than 4 Pa.

In the presence of type B gas appliances with intermittent operation not intended for heating, they must have their own aeration and/or ventilation opening.

The air inlets must meet the following requirements:

- ♦ they must be protected with grids, metal mesh, etc., but without reducing the net useful section;
- ♦ they must be made so as to make the maintenance operations possible;
- ♦ positioned so that they cannot be obstructed;

The clean and non-contaminated air flow can also be obtained from a room adjacent to that of installation (indirect aeration and ventilation), as long as the flow takes place freely through permanent openings communicating with the outside.

The adjacent room cannot be used as a garage, or to store combustible material or for any other activity with a fire hazard, bathroom, bedroom or common room of the building.

FLUE GAS EXHAUST

The heat generator works in depression and is equipped with an outlet fan for flue gas extraction. There must be a single exhaust system for the generator. Using a flue that is shared with other devices is not allowed.

The components of the flue gas exhaust system must be chosen in relation to the type of appliance to be installed in compliance with:

- ♦ UNI/TS 11278 in the event of metal chimneys, with particular attention to that stated in the specification;
- ♦ UNI EN 13063-1 and UNI EN 13063-2, UNI EN 1457, UNI EN 1806 in the event of non-metallic chimneys.
- ♦ The length of the horizontal section must be minimal and, in any case, no longer than 3 metres, with a minimum upward slope of 3%
- ♦ There must not be more than 4 direction changes including the one due to the use of the "T" element.
- ♦ A "T" fitting with a condensation collection cap must be provided at the base of the vertical section.
- ♦ If the exhaust is not inserted in an existing flue, a vertical section with a windproof end piece is required (UNI 10683).
- ♦ The vertical duct can be inside or outside the building. If the smoke duct is inserted in an existing flue, it must be certified for solid fuel.
- ♦ If the smoke duct is outside the building, it must always be insulated.
- ♦ The smoke ducts must have at least one airtight inlet for flue gas sampling.
- ♦ All the sections of the flue gas duct must be accessible to inspection.
- ♦ Inspection openings must be provided for cleaning.
- ♦ If the generator has a fume temperature lower than 160°C+ ambient temperature caused by the high yield (contact technicians) it MUST be resistant to humidity.
- ♦ A flue system that does not respect the previous points or, in general, that does not comply with the regulations, may cause condensation phenomena inside it.

CHIMNEY CAP

The chimney caps must meet the following requirements:

- ♦ they must have a useful outlet section no less than double that of the chimney/ducted system on which it is installed;
- ♦ they must be adapted in order to prevent the penetration of rain and snow in the chimney/ducted system;
- ♦ they must be built so that, in the event of winds coming from all directions and from any angle, the expulsion of combustion products is in any case ensured;

EXAMPLES OF CORRECT CONNECTION TO THE CHIMNEY

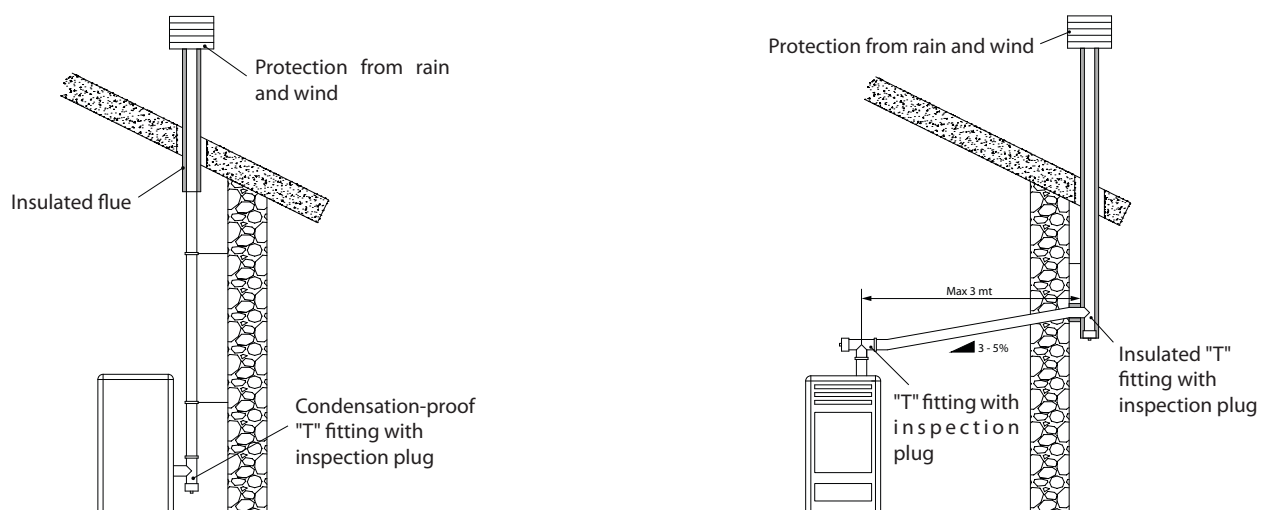

CONNECTION TO THE MAINS ELECTRIC SUPPLY

The generator is supplied with an electric power cable to be plugged into a 230V 50 Hz socket, possibly with a circuit breaker switch. The socket must be easily accessible.

The electrical system must be compliant with standards. The efficiency of the earthing circuit must be checked. Unsuitable earthing of the system can cause malfunctioning for which the manufacturer will not be held liable.

Power supply variations beyond 10% can cause faulty operation of the product.

DETAILS LUCIA

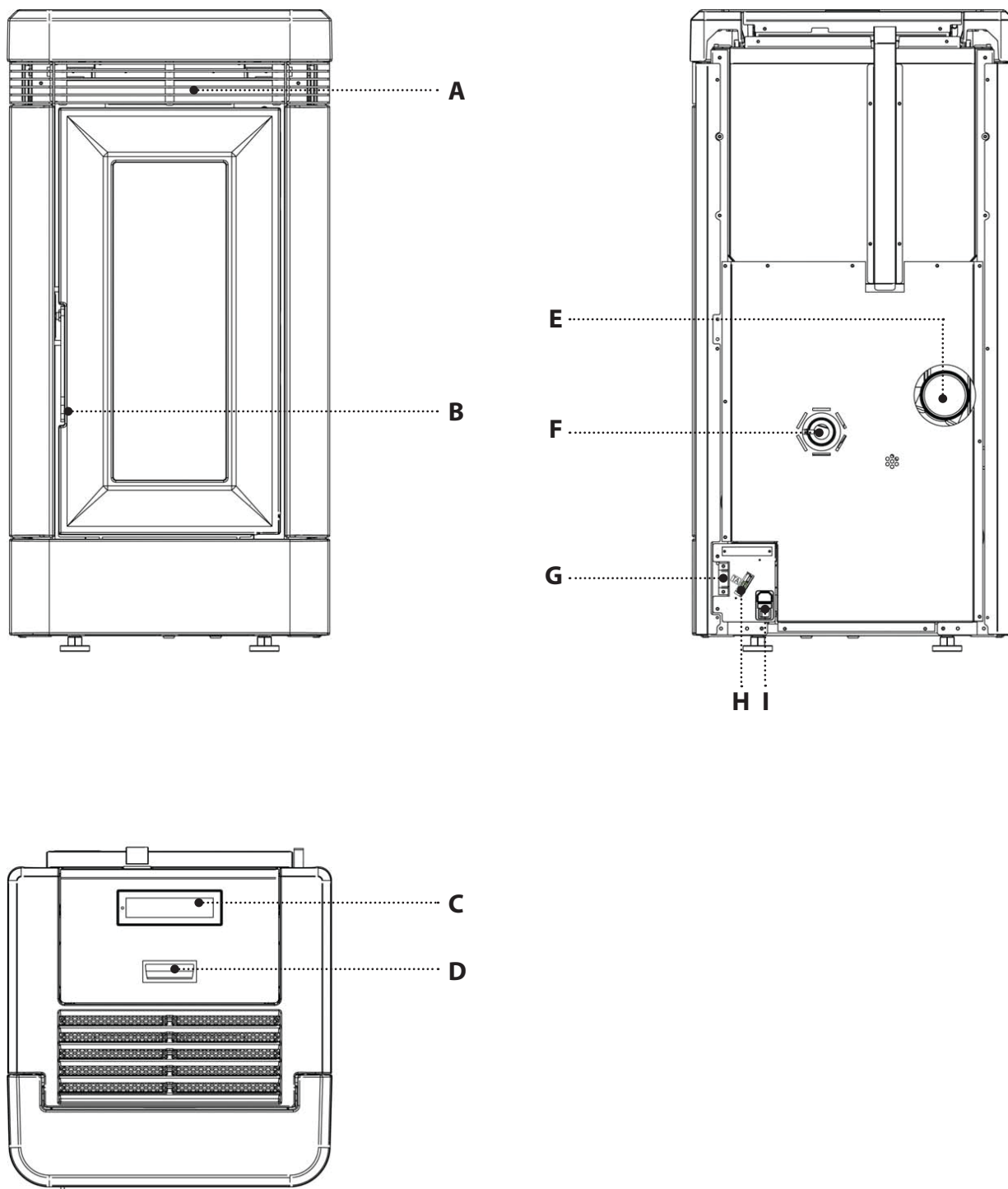

| | | | | | |
|----------|---|----------|----------------------|----------|--------------------------------|
| A | Room air output | E | Fumes exhaust | H | Serial input |
| B | Access to combustion chamber and ash drawer | F | Combustion air inlet | H | Additional thermostat TA input |
| C | Touch screen display | G | Room probe | I | On/Off |
| D | Pressure closing pellet hopper | | | I | Fuse |
| | | | | I | Power supply 230 V |

POSITIONING THE STOVE

For the correct operation of the product, we recommend positioning it on a perfectly flat surface. Use a spirit level to check this.

NOTES FOR CORRECT OPERATION

For the correct operation of the pellet stove, the following indications must be respected:

Both during the functioning and when the stove is not in use, all the machine doors (pellet hopper, fire door, ash drawer) must always remain closed. The machine doors can only be opened for the time required to load the pellet and for maintenance. Failure to comply with that above during operation will cause the display to show the following:

"CLOSE HOPPER-DOOR"

This message indicates that you have 60 seconds to close the hatch/door and pellet lid.

After the 60 seconds, during the ignition phase the stove will go to "DEPR ALARM" mode, while during normal operation the stove will go to "COOLING STAND BY" mode and then re-start automatically when the correct conditions are present (stove cold, etc.).

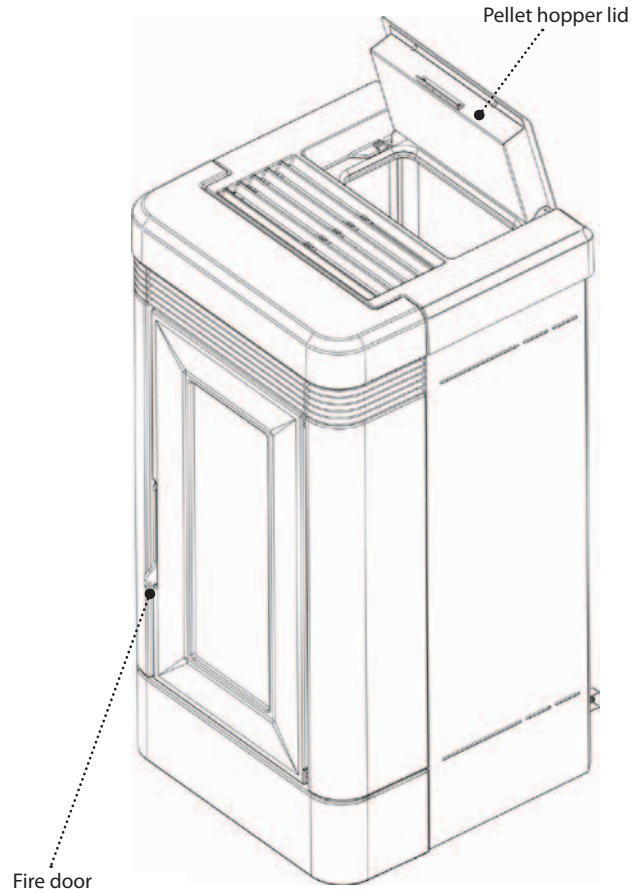

FUSE

If the stove is not powered, check the condition of the fuse in the drawer between the stove switch and the power cord.

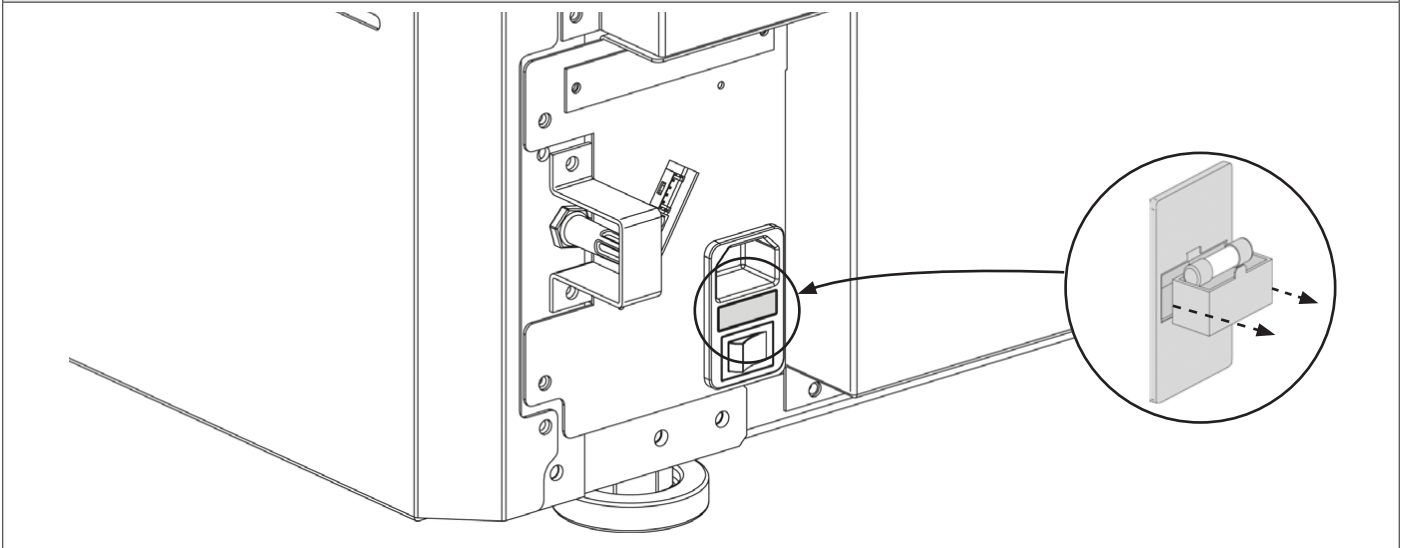

PELLETS AND LOADING

Pellets are made by subjecting wood shavings i.e. the rejects of pure unpainted wood from sawmills, carpentry products and products from other activities connected to wood working and transformation, to very high pressures.

This type of fuel is fully ecological as no glues are used for its compaction. In fact, pellet compactness is guaranteed over time by a natural substance found in wood: lignite.

In addition to being an ecological fuel, making best use of wood residue, pellets also have a series of technical advantages.

While wood has a calorific value of 4.4 kWh/kg (with 15% moisture, therefore after approximately 18 months of curing), that of pellets is 5 kWh/kg.

Pellet density is about 650 kg/m³ and water content is equal to 8% of its weight. For this reason pellets do not need to be cured to obtain a sufficient heat yield.

The pellets used must comply with the characteristics described by the following standards:

EN PLUS class A1, ISO 17225-2 class A1

and

UNI EN 303-5 with the following characteristics: water content ≤ 12%, ash content ≤ 0.5% and lower calorific value >17 MJ/kg (in the case of boilers).

The manufacturer always recommended using pellets with a diameter of 6 mm with its products.

PELLET STORAGE

In order to ensure problem-free combustion pellets must be stored in a dry place.

Open the tank lid and load the pellets using a scoop.

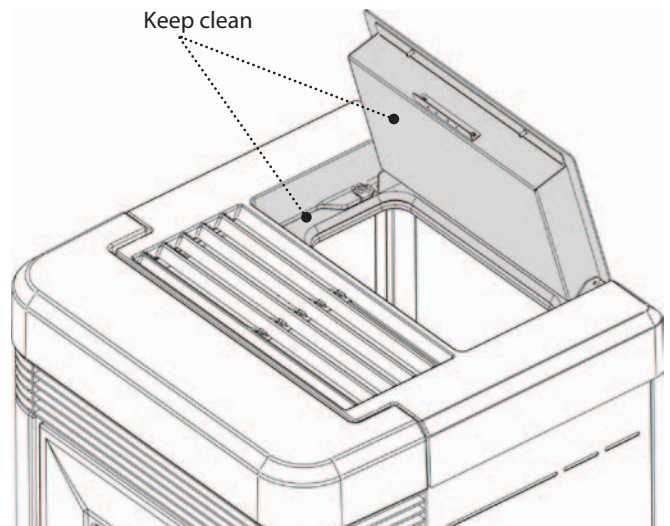

THE USE OF POOR QUALITY PELLETS OR ANY OTHER MATERIAL WILL COMPROMISE STOVE FUNCTIONS, VOIDING THE WARRANTY AND RELEASING THE MANUFACTURER OF LIABILITY.

PELLET HOPPER - PRESSURISED CLOSURE.

During stove operation, the pellet hopper lid must always be closed.

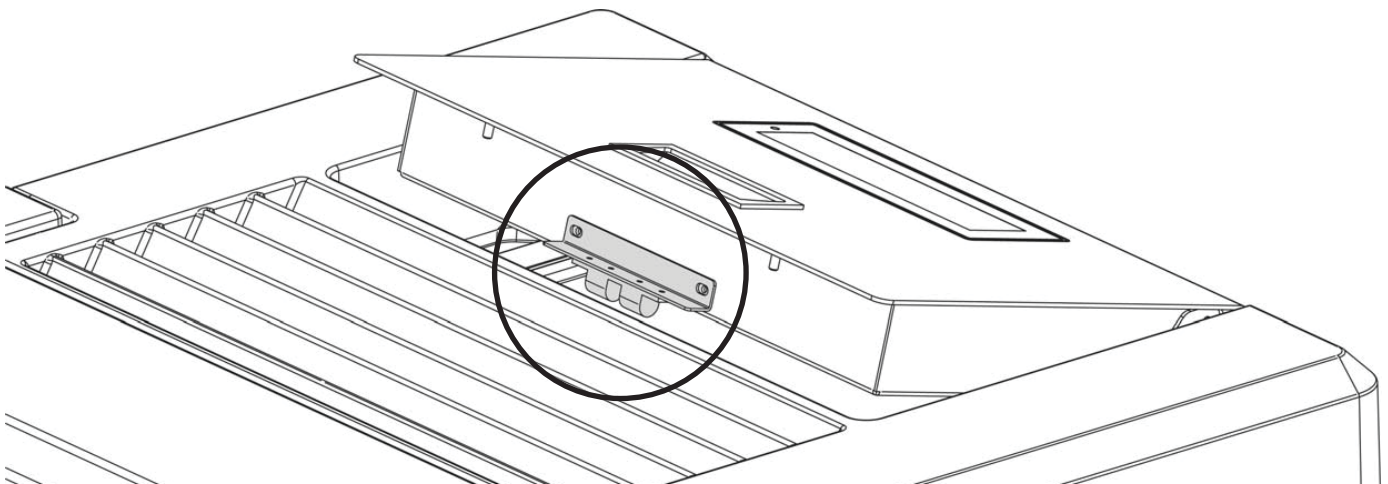

DO NOT PLACE THE BAG DIRECTLY ON THE STOVE TO LOAD THE TANK. ALWAYS USE A SCOOP TO LOAD THE TANK. DO NOT RUB OR PLACE WEIGHTS ON THE TANK SEAL. KEEP THE TANK COVER SEAL SUPPORTING SURFACE CLEAN AT ALL TIMES. CHECK THE CONDITIONS OF THE SEAL FREQUENTLY. IF DAMAGED, CONTACT YOUR LOCAL AUTHORISED TECHNICIAN.

REMOTE CONTROL



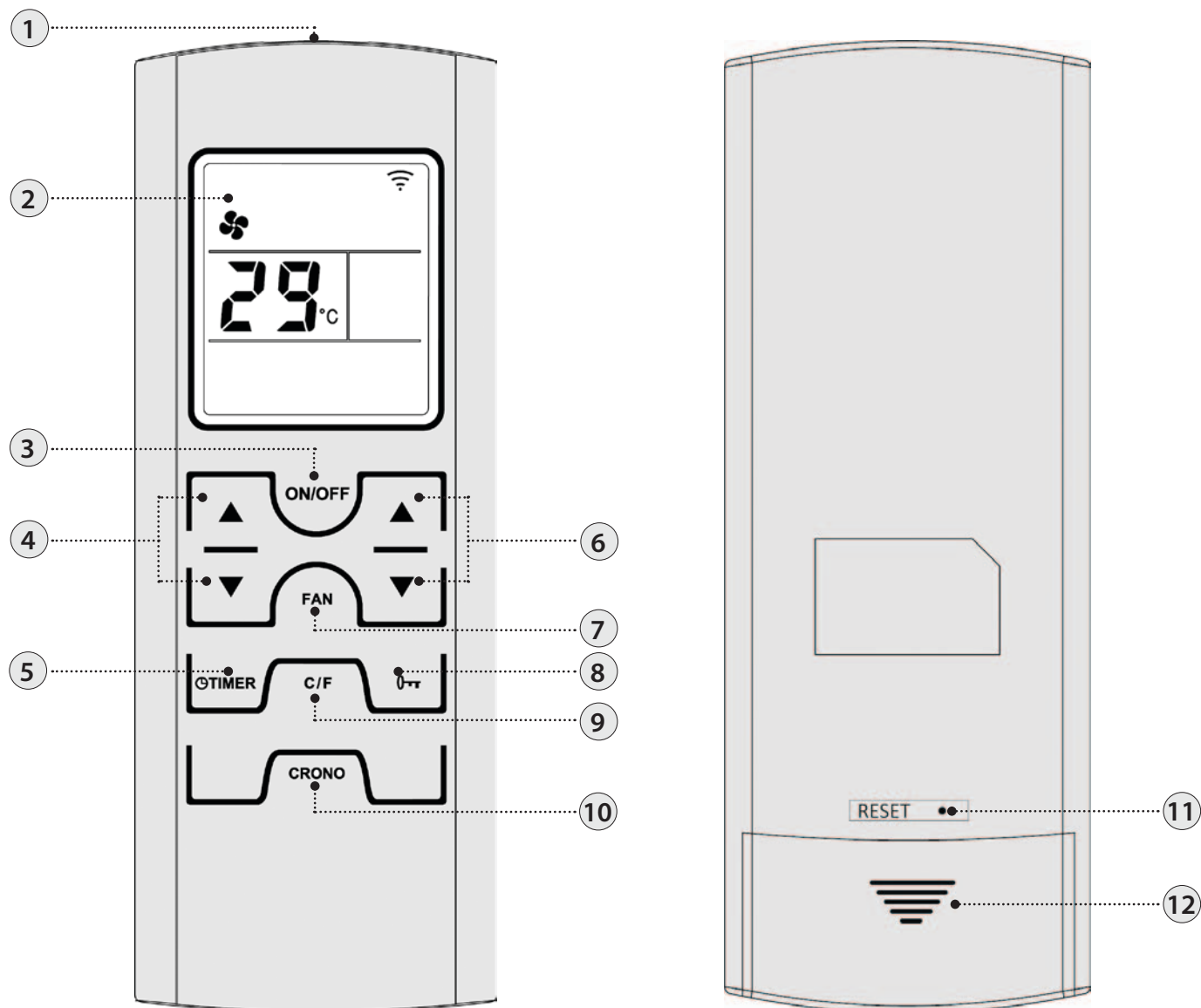



The remote control can be used to adjust the main stove functions.



| | | | |
|----------|--|-----------|---|
| 1 | Transmitter | 7 | Select air mode |
| 2 | Display | 8 | Lock keyboard |
| 3 | On/off stove (hold for 3 seconds) | 9 | Degrees Celsius / Fahrenheit |
| 4 | Set power | 10 | Press the button once to enable or disable the chrono |
| 5 | Set switch-off delay: The button allows to set the switch-off delay. For example, if you set it to one hour, the stove will automatically switch off after the set time * | 11 | Reset* |
| 6 | Set room temperature | 12 | Battery compartment |

* not available in this model

REMOTE CONTROL ICONS

| | | | |
|--|--|--|---|
|  | Air mode selected: Flashing COMFORT On AUTO |  | Enable chrono Light on = activated Light off = deactivated |
| OFF TIME  | Set switch-off delay |  | Indicates the transmission of the radio signal On = during all radio communication Off = radio communication absent |
|  | Battery low |  | Keys locked |
|  | Set power level. The power level is displayed, instead of the set room temperature, for 3 seconds when one of the set power buttons is pressed (4). | | |

INSERTING THE BATTERIES

Remove the battery compartment cover by sliding it down. Insert 2 AAA batteries.

Insert the batteries respecting the correct polarity (+) and (-).
Close the cover of the battery compartment.

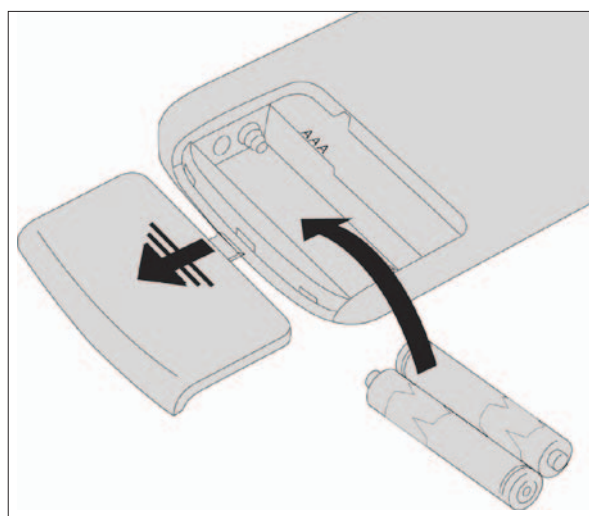

IF THE REMOTE CONTROL IS SWITCHED OFF DUE TO NO BATTERY INSTALLED, THE STOVE CAN BE CONTROLLED FROM THE COMMAND PANEL LOCATED ON THE UPPER PART OF THE STOVE. WHEN CHANGING THE BATTERIES, MAKE SURE YOU FOLLOW THE SYMBOLS PRINTED INSIDE THE REMOTE CONTROL.



Respect the environment!

Used batteries contain metals that are harmful to the environment, and therefore must be disposed of separately in special containers.

ADVICE AND PRECAUTIONS FOR THE USE OF THE REMOTE CONTROL

- ◆ Remove the batteries if it is not used for a long time.
- ◆ When being used, direct it towards the stove's signal receiver.
- ◆ Handle the remote control with care. When it is not being used, place it on the special base supplied.
- ◆ The remote control must not be left in a place where it is exposed to direct sunlight or near a source of heat.
- ◆ The quality of the signal may be affected by other IR sources.

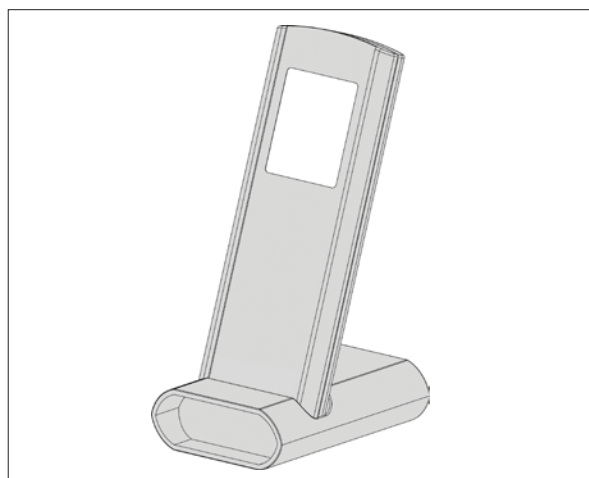

THE REMOTE CONTROL IS FITTED WITH AN LCD BACKLIT DISPLAY. THE BACKLIGHTING LASTS 20 SECONDS FROM THE LAST PRESS OF A BUTTON. AFTER A CERTAIN TIME, TO SAVE BATTERY POWER, THE DISPLAY TURNS OFF (ENERGY SAVING MODE).

THE CONTROL FUNCTIONS ARE REACTIVATED WHEN THE REMOTE IS REMOVED FROM ITS UNIT OR BY A LONG PRESS OF THE BUTTON.

TOUCH SCREEN DISPLAY

The stove is equipped with a modern touch screen display with WiFi technology that allows for the individual functions of the unit to be adjusted by the user in an easy and intuitive manner.

Touch the buttons (icons) on the display to activate the actions. The touch screen display reacts with the touch of your fingers.

WARNING!

- Do not use screen protectors: the display might not work properly
- Do not place the touch screen display in direct or indirect contact with water. The touch screen display may not work properly in the presence of humidity or if it is exposed to water.
- To avoid damaging the touch screen display, do not touch it with sharp objects and do not press it too hard with your fingers.
- While opening and closing, only press the external frame of the Display.

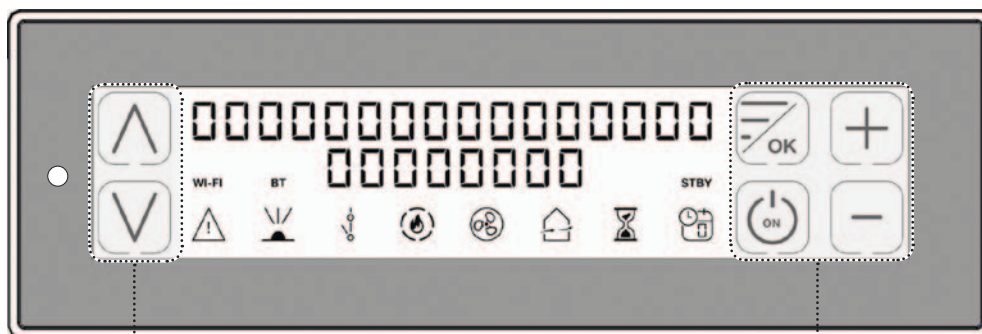

TOUCH.SENSITIVE PARTS



DISPLAY OPENING

Unlock the display by pressing on the edges of the display (A). Lift the display until it clicks.

DISPLAY CLOSING

Unlock the display by moving the lever behind the display (B). Lower the display as shown in the figure (A) until it closes completely.

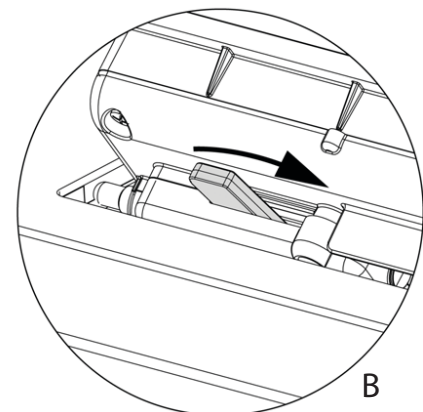
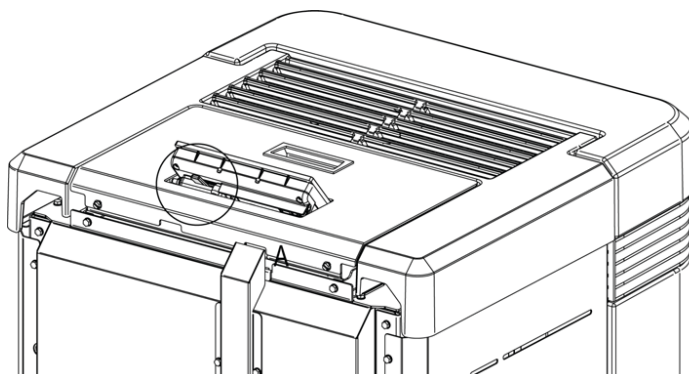
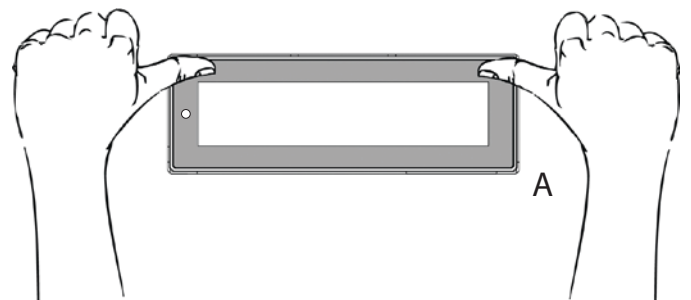

| FREQUENCY BANDS | MAXIMUM POWER TRANSMITTED |
|-----------------|---------------------------|
| WiFi | 20.0 DBM |
| BLUETOOTH | Class-3 |

CONTROL PANEL

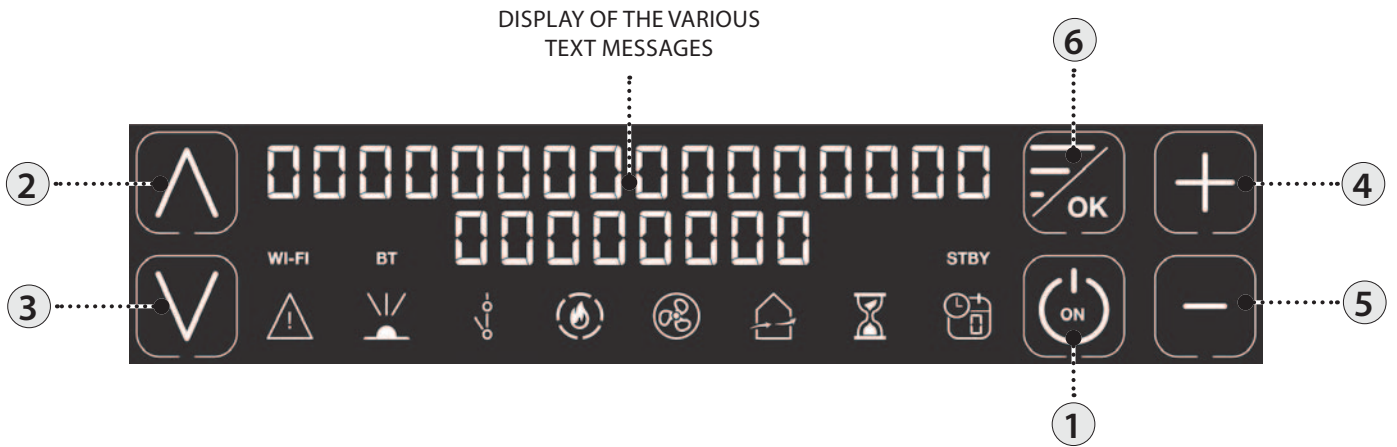

- ① On/off stove.
- ② Increase operating power / scroll through the menus.
- ③ Decrease operating power / scroll through the menus.
- ④ Increase operating set thermostat / scroll through the menus.
- ⑤ Decrease operating set thermostat / scroll through the menus.
- ⑥ To access the menu / confirm key.

| ICON KEY | | | |
|----------|---|-------|--|
| | Indicates the presence of an alarm. Off: indicates that there are no alarms On: indicates the presence of an alarm | | Delayed switch-off icon. Off: deactivated. On: activated. |
| | Indicates the reception of the IR signal On = IR command received Off = IR communication absent | | It indicates the status of the weekly programming Off: deactivated. On: activated. The number indicates the current reference time frame. |
| | Indicates contact of the external additional thermostat Closed contact: the contact of the external additional thermostat is closed. Open contact: the contact of the external additional thermostat is open. | WI-FI | WiFi icon Off: deactivated. On: activated and connected to the home network. Flashing: activated but not connected to the home network. |
| | Indicates the stove power. Flame on: stable power. Flame flashing: the power is changing. The dashes indicate the actual power of the machine. | STBY | STAND-BY function icon Off: deactivated. On: activated. |
| | It indicates the operation of the tangential fan. Off = ventilation not active. On = ventilation active. Flashing: ventilation at reduced speed for compensation. | | It indicates the operation of the pump. Off = pump stopped. On = pump active. Flashing = electronic anti-condensation function active. |

MAIN MENU



- ① Back - exit
- ② ③ Scroll through parameters: next (3); previous (2)
- ④ ⑤ Change settings data: increase (4); decrease (5)
- ⑥ Confirm - access Menu

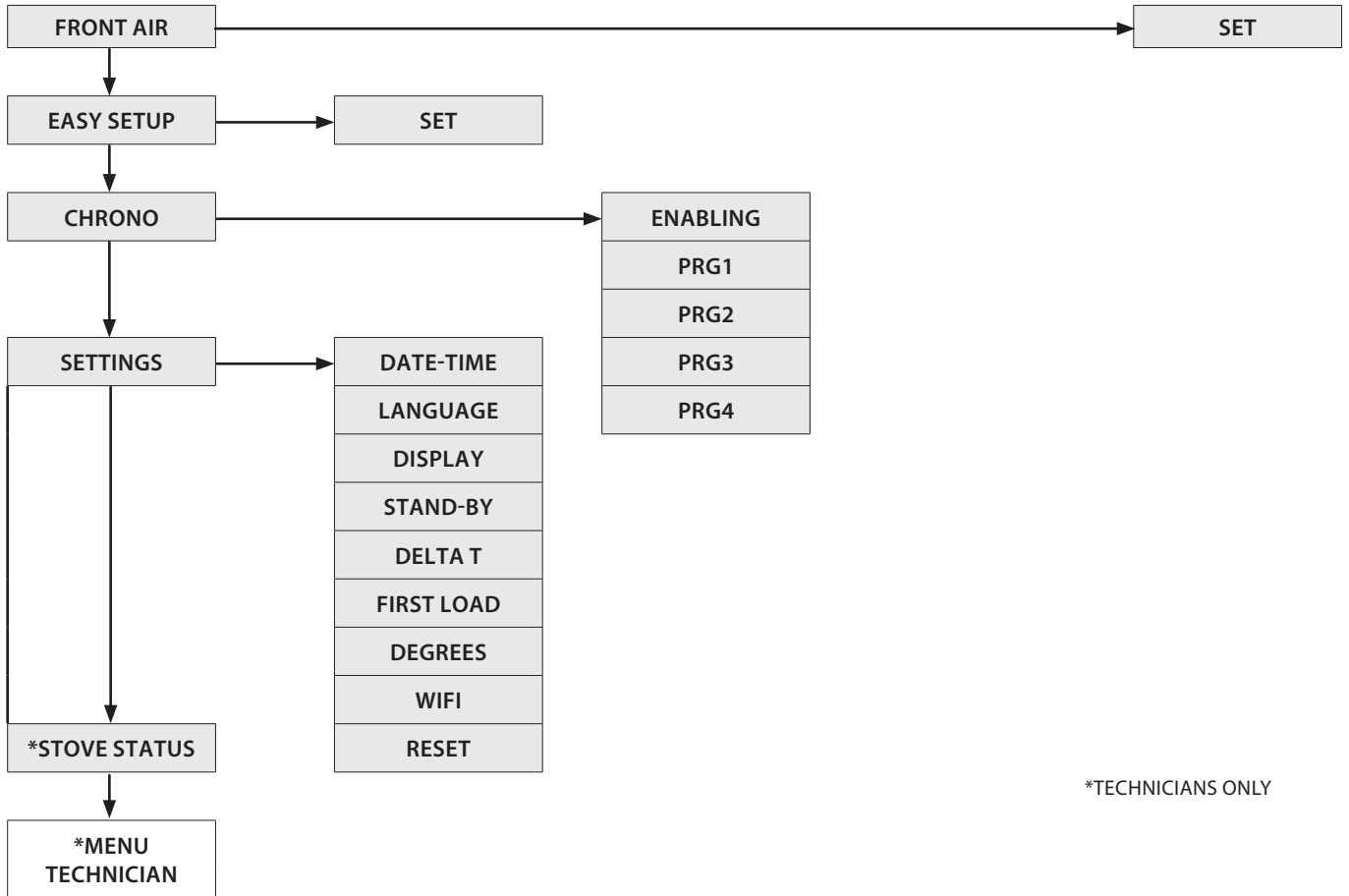

*TECHNICIANS ONLY

GENERAL WARNINGS

Advice to follow for the first start-ups of the product:

During the first hours of operation, there may be some smoke or odours, but they are due to the normal "thermal break-in" process. During this process, the duration of which changes depending on the product, it is recommended to:

- ◆ Ventilate the room well
- ◆ If present, remove any majolica parts from the top of the product
- ◆ Activate the product at the maximum power and temperature
- ◆ Avoid remaining in the room for a long time
- ◆ Do not touch the surfaces of the product

Notes:

The process is completed after a few heating/cooling cycles. Do not use for the combustion of elements or substances other than those indicated in the manual.

Before turning on the product, it is necessary to perform the following checks:

- ◆ If it is intended to be connected to a hydraulic system, it must be complete and fully functional and in compliance with the instructions given in the product manual and with the relevant regulations in force.
- ◆ The pellet hopper must be completely loaded
- ◆ The combustion chamber and the burn pot must be clean
- ◆ Make sure that the fire holder, the ash pan and the pellet hopper close hermetically (if present in the hermetic version); they must be closed and there must be no foreign bodies in the sealing elements and gaskets.
- ◆ Check that the power cord is properly connected
- ◆ The bipolar switch (if present) must be set to position "1".



MAKE SURE THAT THERE ARE NO RESIDUES OR DIRT AT THE BOTTOM OF THE BURN POT. THE HOLES AT THE BOTTOM MUST BE COMPLETELY CLEAR, TO ENSURE PROPER COMBUSTION. THE "EASY SETUP" FUNCTION CAN BE USED TO ADAPT COMBUSTION ON THE BASIS OF THE NEEDS DESCRIBED.

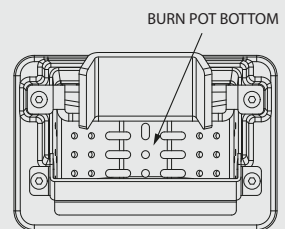

SETTINGS FOR FIRST USE

After connecting the power cord at the back of the stove, turn the switch located at the back to position (I).
The switch at the back of the stove is used to power the generator board.
The stove will remain off and the word OFF will appear on the panel.

DATE-TIME

This menu allows you to set the time and date.

CONTROLS PROCEDURE

- ◆ Press 6.
- ◆ Press 3 until **SETTINGS** appears and confirm by pressing 6.
- ◆ Confirm **DATE-TIME** by pressing 6 and using 4 and 5 to set the day.
- ◆ Keep pressing 6.
- ◆ Use keys 4 or 5 to set and 6 to move forward, to set the day, time, minutes, date, month, year.
- ◆ Press 6 to confirm or 1 to return to the previous menus to the initial state.

LANGUAGE

This menu allows the preferred language to be selected.

The available languages are: Italian - English - German - French - Spanish - Portuguese - Danish - Estonian - Croatian - Slovenian - Dutch - Polish.

CONTROLS PROCEDURE

- ◆ Press 6.
- ◆ Press 3 until **SETTINGS** appears and confirm by pressing 6.
- ◆ Press 3 until **LANGUAGE** appears and confirm by pressing 6.
- ◆ Select the language using keys 4 or 5.
- ◆ Press 6 to confirm or 1 to return to the previous menus to the initial state.

DEGREES

This menu allows you to set the unit of measurement for the temperature. The preset value is °C.

CONTROLS PROCEDURE

- ◆ Press 6.
- ◆ Press 3 until **SETTINGS** appears and confirm by pressing 6.
- ◆ Press 3 until **DEGREES** appears and confirm by pressing 6.
- ◆ Use keys 4 -5 to select Celsius or Fahrenheit.
- ◆ Press 6 to confirm or 1 to return to the previous menus to the initial state.



NO IGNITION

THE FIRST IGNITION MAY FAIL, SINCE THE AUGER IS EMPTY AND IT IS NOT ALWAYS POSSIBLE TO FILL THE BURN POT WITH THE RIGHT AMOUNT OF PELLETS TO START THE FLAME REGULARLY. IF THE PROBLEM OCCURS ONLY AFTER A FEW MONTHS OF OPERATION, MAKE SURE THAT THE ROUTINE CLEANING OPERATIONS INDICATED ON THE STOVE BOOKLET HAVE BEEN CARRIED OUT PROPERLY

OPERATION AND LOGIC

IGNITION

After checking the previous points, press the 1 for three seconds to switch on the stove. For the ignition phase, 15 minutes are available during which the presence of the flame is checked. When the control temperature has been reached, the stove stops the ignition phase and goes into PREPARATION.

PREPARATION

During the preparation phase, the stove stabilises and gradually increases combustion, and then activates the ventilation and goes into WORK

WORK

During the work phase, the stove reaches the Set Power defined by the user, heating the room until the Set Thermostat has been reached. See following note.

SET THERMOSTAT

The Set room thermostat can be set using keys 4 and 5, from LOW-TA - 7°C - 37°C - HOT. If the value is between 7°C - 37°C, the stove checks the room temperature using a probe on the machine. Once the set temperature has been reached, the stove automatically reduces the power ensuring optimal comfort and reducing the consumption of pellets: this process is called "modulation".

LOW-TA / HOT

If the Set Thermostat is "LOW-TA" (set below the 7° threshold) the temperature is checked by the additional thermostat contact, thus ignoring the temperature probe on the machine.

If the contact is open (met), the stove operates at the minimum value.

If the contact is closed (required), the stove operates at the set power.

If the setting is on "HOT" (set above 37°C) the stove always operates at the set power, ignoring the external contact and the temperature probe.

SET POWER

The Set Power has 5 levels of operation. The power can be changed using keys 2 or 3.

Power 1 = minimum level - Power 5 = maximum level.

The change is saved after exiting by pressing 1.

BLOW

During the work phase and at regular time intervals, the stove cleans the burn pot by means of an operation called "BLOW".

The activation of this function is shown on the display with the relative message. During the "BLOW" the pellet loading is slowed down and the fumes motor is increased.

After the cleaning phase, the stove goes back to the normal operating conditions.

SWITCH-OFF

Press 1 for three seconds.

After performing this operation, the appliance automatically enters the switch-off phase, and stops loading pellets.

The fumes motor and the hot air fan motor remain on until the stove temperature falls below the safety threshold.

RE-IGNITION

The stove can be switched back on only if the fume temperature is lower than a preset threshold and if a minimum safety time has elapsed.



NEVER USE FLAMMABLE LIQUIDS FOR IGNITION!

WHILE FILLING, DO NOT BRING THE PELLET BAG IN CONTACT WITH THE BOILING STOVE!

IN CASE OF CONTINUOUS FAILED IGNITIONS, CONTACT AN AUTHORISED TECHNICIAN.



DO NOT USE THE APPLIANCE WITHOUT THE SEPARATOR AND/OR FLAME GUARD (SEE FIGURE TO THE SIDE). REMOVING THEM WILL AFFECT THE SAFETY OF THE PRODUCT AND WILL INVALIDATE THE WARRANTY IMMEDIATELY. IN THE EVENT OF WEAR OR DETERIORATION, REQUEST THE REPLACEMENT OF THE PART FROM THE SERVICE CENTRE (THIS TYPE OF REPLACEMENT IS NOT COVERED BY WARRANTY BECAUSE IT IS A COMPONENT SUBJECT TO WEAR).

FLAME GUARD SEPARATOR

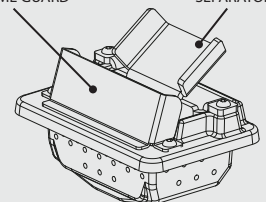

FRONT AIR

This menu allows you to set the front air motor speed. Range: (comfort, auto).

If you select comfort mode, the front air speed is reduced

To ensure combustion efficiency, the front air is excluded when the product is at the minimum power.

CONTROLS PROCEDURE

- ◆ Press 6.
- ◆ Confirm **FRONT AIR** by pressing 6.
- ◆ Use keys 4 -5 to set the desired mode.
- ◆ Press 6 to confirm or 1 to return to the previous menus to the initial state.

EASY SETUP

The volumetric weight of the pellet is the ratio between the weight and the volume of the pellet. This ratio may change while keeping the quality of the pellet unchanged. Use the EASY SETUP function to change the calibration of the volumetric weight by increasing or decreasing the preset values.

In the stove program, the available values from "- 3" to "+ 3"; all stoves are calibrated in production with the optimal value which is 0.

If you notice an excessive deposit on the burn pot, enter the EASY SETUP program and reduce the value to "- 1"; then wait the following day and if you do not see an improvement reduce it even more up to a maximum of "- 3".

If, on the other hand, it is necessary to increase the calibration of the volumetric weight of the pellet, switch the factory value from "0" to "+ 1, + 2, + 3" as required.

| EXCESSIVE PELLETT DEPOSIT IN THE BURN POT | | | NORMAL OPERATION | MINIMUM PELLETT DEPOSIT IN THE BURN POT | | |
|--|--|---------------------------------------|-----------------------|---|--|--|
| -3 | -2 | -1 | 0 | +1 | +2 | +3 |
| THIRD DECREASE RANGE IF THE FIRST TWO ARE NOT ENOUGH | SECOND DECREASE RANGE IF THE FIRST IS NOT ENOUGH | FIRST DECREASE RANGE (TEST FOR 1 DAY) | OPTIMAL FACTORY VALUE | FIRST INCREASE RANGE | SECOND INCREASE RANGE IF THE FIRST IS NOT ENOUGH | THIRD INCREASE RANGE IF THE FIRST TWO ARE NOT ENOUGH |

CONTROLS PROCEDURE

- ◆ Press 6.
- ◆ Press key 3 until **EASY SETUP** appears and confirm by pressing key 6.
- ◆ Use keys 4 -5 to set the range.
- ◆ Press 6 to confirm or 1 to return to the previous menus to the initial state.

N.B.: IF THIS CALIBRATION DOES NOT SOLVE THE PELLETT DEPOSIT IN THE BURN POT, PLEASE CONTACT YOUR LOCAL SERVICE CENTRE.

CHRONO



This function allows you to program the stove to switch on and off automatically.
The factory setting for **CHRONO** is off.

The chrono allows you to program 4 time slots within a day to be used for every day of the week.

In each time slot, it is possible to set the ignition and switch-off times, the days of use of the programmed time slot, the desired temperature and the set power. The current date and time setting is essential for the correct operation of the timer.

Recommendations

Before using the chrono function, you must set the current day and time, so check that you have followed the points listed in the sub-chapter "DATE-TIME". To make sure that the chrono function works properly, as well as programming it, it is also necessary to activate it. The 4 time slots can be overlapped by setting the ignition and switch-off times. In this way, a combination of times is obtained in which it is possible to set different temperatures and powers without affecting the operating status of the stove.

N.B.: if there are overlapped time slots, the product will remain on until the furthest switch-off time.

ENABLING/DISABLING THE CHRONO

CONTROLS PROCEDURE

- ◆ Press 6.
- ◆ Press 3 until **CHRONO** appears and confirm by pressing key 6.
- ◆ Confirm **ENABLING** by pressing 6.
- ◆ Use keys 4 -5 to enable (**ON**) or disable (**OFF**)
- ◆ Press 6 to confirm or 1 to return to the previous menus to the initial state.

| | | | | | | |
|---------------|---|-----------------|---|------------------------|--------------------------|---------------------------------|
| CHRONO | > | ENABLING | > | PRG1 | On/off | Enable/disable PRG 1 |
| | | ∨ | | PRG2 | On/off | Enable/disable PRG 2 |
| | | ∨ | | PRG3 | On/off | Enable/disable PRG 3 |
| | | ∨ | | PRG4 | On/off | Enable/disable PRG 4 |
| | | PRG1 | > | START PRG1 | OFF-00:00 | Ignition time PRG1 |
| | | ∨ | | STOP PRG1 | OFF-00:00 | Switch-off time PRG1 |
| | | ∨ | | MONDAY...SUNDAY | On/off | Enable/disable the days of PRG1 |
| | | ∨ | | SET PRG1 | LOW-TA - 07- 37 °C - HOT | Set thermostat PRG1 |
| | | ∨ | | POWER PRG1 | 1-5 | Set power PRG1 |
| | | PRG2 | > | START PRG2 | OFF-00:00 | Ignition time PRG2 |
| | | ∨ | | STOP PRG2 | OFF-00:00 | Switch-off time PRG2 |
| | | ∨ | | MONDAY...SUNDAY | On/off | Enable/disable the days of PRG2 |
| | | ∨ | | SET PRG2 | LOW-TA - 07- 37 °C - HOT | Set thermostat PRG2 |
| | | ∨ | | POWER PRG2 | 1-5 | Set power PRG2 |
| | | PRG3 | > | START PRG3 | OFF-00:00 | Ignition time PRG3 |
| | | ∨ | | STOP PRG3 | OFF-00:00 | Switch-off time PRG3 |
| | | ∨ | | MONDAY...SUNDAY | On/off | Enable/disable the days of PRG3 |
| | | ∨ | | SET PRG3 | LOW-TA - 07- 37 °C - HOT | Set thermostat PRG3 |
| | | ∨ | | POWER PRG3 | 1-5 | Set power PRG3 |
| | | PRG4 | > | START PRG4 | OFF-00:00 | Ignition time PRG4 |
| | | | | STOP PRG4 | OFF-00:00 | Switch-off time PRG4 |
| | | | | MONDAY...SUNDAY | On/off | Enable/disable the days of PRG4 |
| | | | | SET PRG4 | LOW-TA - 07- 37 °C - HOT | Set thermostat PRG4 |
| | | | | POWER PRG4 | 1-5 | Set power PRG4 |



IF THE WEEKLY CHRONO IS ACTIVE ON THE CONTROL PANEL, A SMALL ICON IS DISPLAYED



EXAMPLE OF TIMER WITH OVERLAPPING TIME SLOTS

TIME SLOT

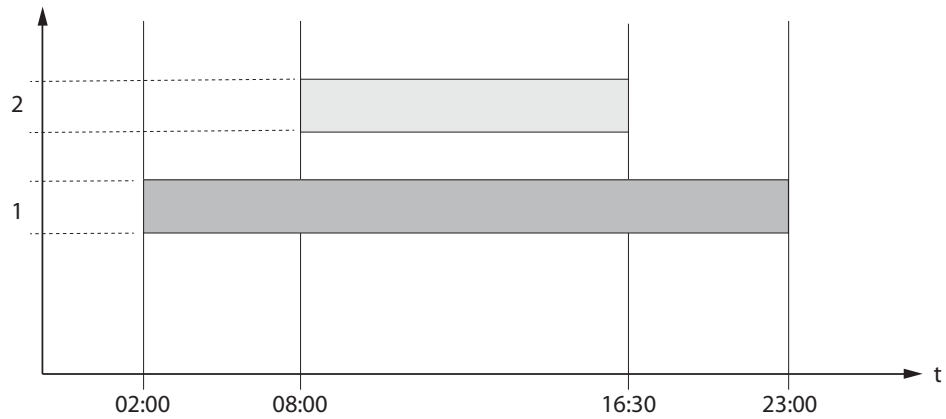

SET POWER

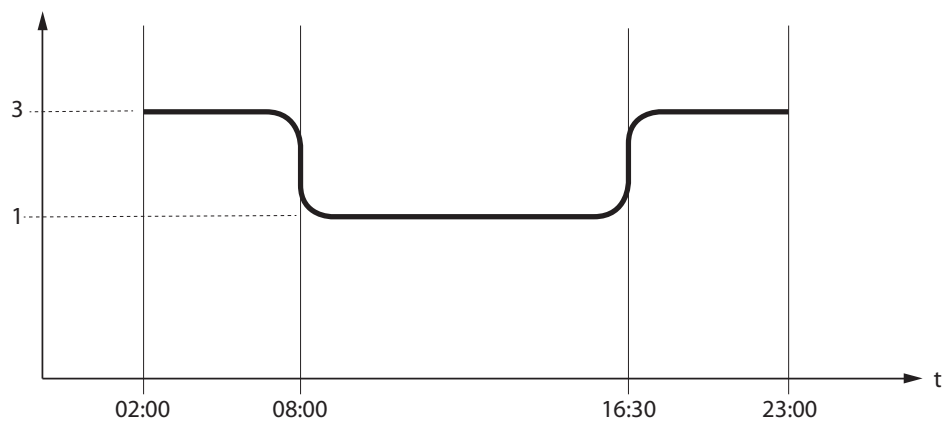

SET THERMOSTAT

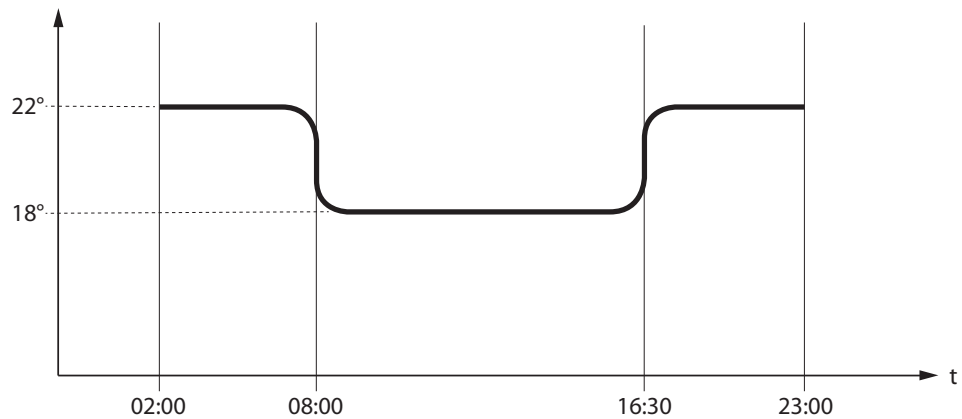

| | | | |
|---|-----------------|---------------------------|-------------------------------|
|  | Time slot 1 | start 02:00 stop 23:00 | power 3 - SET THERMOSTAT 22°C |
|  | Time slot 2 | start 08:00 stop 16:30 | power 1 - SET THERMOSTAT 18°C |
|  | stove operation | | |

SETTINGS

- **DATE-TIME**
- **LANGUAGE**
- **DEGREES**

SEE CHAPTER: SETTINGS FOR FIRST USE

DISPLAY

This menu allows you to adjust the brightness of the display. The possible values go from OFF, 1 to 20. If OFF, the display backlight is at the maximum intensity and goes out after a 60 second delay.

The backlight comes back on when a key is pressed or if an alarm is generated.

CONTROLS PROCEDURE

- ◆ Press 6.
- ◆ Press 3 until **SETTINGS** appears and confirm by pressing 6.
- ◆ Keep pressing 3 until **DISPLAY** appears and confirm by pressing 6.
- ◆ Use keys 4 -5 to set the desired intensity.
- ◆ Press 6 to confirm or 1 to return to the previous menus to the initial state.

STAND - BY

If enabled, the **STAND-BY** function is used to switch off the machine from the additional thermostat

CONTROLS PROCEDURE

- ◆ Press 6.
- ◆ Press 3 until **SETTINGS** appears and confirm by pressing 6.
- ◆ Keep pressing 3 until **STAND-BY** appears and confirm by pressing 6.
- ◆ Use keys 4-5 to enable (ON) / disable (OFF).
- ◆ Press 6 to confirm or 1 to return to the previous menus to the initial state.

STAND-BY FUNCTION ON

If the **STAND-BY** function is active (ON), if the room temperature exceeds the value of the **SET THERMOSTAT + DELTA T OFF**, then the stove will switch off after a preset delay, displaying **STAND-BY**.

When the room temperature is lower than the **SET THERMOSTAT - DELTA T** and after a possible cooling time, the stove switches back on.

STAND-BY FUNCTION OFF (FACTORY SETTING)

If the **STAND-BY** function is not active (OFF), if the stove exceeds the set room temperature it will switch to the minimum value, modulating and displaying **MODULATION**. When the room temperature is lower than the **SET THERMOSTAT** the stove goes back to operating at the set power, displaying **WORK**.

OPERATION WITH ADDITIONAL THERMOSTAT (OPTIONAL)

STAND-BY FUNCTION OFF (FACTORY SETTING)

If the **STAND-BY** function is not active (OFF), if the stove exceeds the room temperature set on the additional thermostat (contact open) it will switch to the minimum value, displaying **MODULATION**. When the room temperature is lower than the value set on the additional thermostat (contact closed), the stove goes back to operating at the set power, displaying **WORK**.

STAND-BY FUNCTION ON

When the **STAND-BY** function is active (ON), when the room temperature set on the additional thermostat has been reached (contact open), the stove will switch off after a preset delay, displaying **STAND-BY**.

When the room temperature is lower than the value set on the additional thermostat (contact closed) and after a possible cooling time, the stove switches back on.



**FOR CORRECT OPERATION, SET THE SET THERMOSTAT TO LOW-TA.
> SEE CHAPTER ON THE ADDITIONAL THERMOSTAT SETTINGS**

ADDITIONAL THERMOSTAT

N.B. : THE INSTALLATION MUST BE PERFORMED BY AN AUTHORISED TECHNICIAN

There is a possibility to thermostat a room adjacent to the room where the stove has been placed; simply connect a thermostat following the procedure described in the following section (it is advisable to place the optional mechanical thermostat at a height from the ground equal to 1.50 m). Stove operation with the external thermostat connected in the TA terminal can be different depending on the activation or deactivation of the STAND-BY function.

INSTALLATION OF ADDITIONAL THERMOSTAT

- ♦ Turn off the appliance via the main switch on the back of the stove.
- ♦ Remove the plug from the power outlet.
- ♦ Connect the two cables of the thermostat on the terminal (TA) behind the machine.

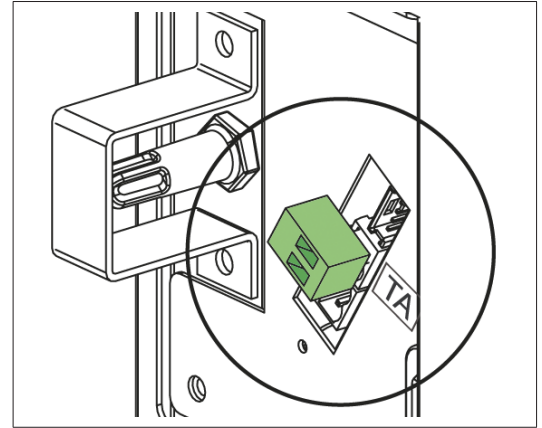

FOR CORRECT OPERATION, SET THE SET ROOM THERMOSTAT TO LOW-TA

DELTA T

This function allows you to set the hysteresis to switch the stove on and off *DELTA T*, used as a room temperature adjustment interval if not managed by an external thermostat. The exact temperature for ignition is *SET THERMOSTAT - DELTA T*. The temperature for switch-off is *SET THERMOSTAT + DELTA T*.

The possible values for *DELTA T* go from: 0.5 - 5°C

CONTROLS PROCEDURE

- ♦ Press 6.
- ♦ press 3 until **SETTINGS** appears and confirm by pressing 6
- ♦ Press 3 until **DELTA T** appears and confirm by pressing 6.
- ♦ Use keys 4 -5 to set the desired value.
- ♦ Press 6 to confirm or 1 to return to the previous menus to the initial state.

FIRST LOAD

This function allows to fill the auger, facilitating the first start-up phases of the stove, or in the event that the pellet hopper is empty. With the stove cold and "OFF", make sure the pellet has been introduced inside the tank and activate the **FIRST LOAD** function, confirming with OK. **To stop the continuous loading, simply press 1 for 3 seconds.**

CONTROLS PROCEDURE

- ♦ Press 6.
- ♦ press 3 until **SETTINGS** appears and confirm by pressing 6.
- ♦ Keep pressing 3 until **FIRST LOAD** appears and confirm by pressing 6.
- ♦ Use keys 4-5 to enable "ON" / disable "OFF"
- ♦ Press 1 several times to confirm and exit the menu.

WI-FI

The display allows internet connection using Wi-Fi technology.

This allows remote management and control of the stove using the dedicated APP for Smartphones, "TotalControl 2.0" (Apple Store / Play Store).



ATTENTION DOWNLOAD:
"TOTAL CONTROL 2.0" APP

The Wi-Fi network can be configured directly from the display using the following procedure (Home network configuration).

WI-FI ENABLING CONTROLS PROCEDURE

- ◆ Press 6.
- ◆ Press 3 until **SETTINGS** appears and confirm by pressing 6.
- ◆ Keep pressing 3 until **Wi-Fi** appears and confirm by pressing 6.
- ◆ Press 6 to access **ENABLING**.
- ◆ Use keys 4-5 to select enabling "ON"/ disabling "OFF" and press 6 to confirm.
- ◆ Press 1 several times to exit the menu.

WIFI CONFIGURATION RESET CONTROLS PROCEDURE AND ACCESS POINT ACTIVATION

- ◆ Press 6.
- ◆ Press 3 until **SETTINGS** appears and confirm by pressing 6.
- ◆ Keep pressing 3 until **Wi-Fi** appears and confirm by pressing 6.
- ◆ Press 3 until **RESET** appears and confirm by pressing 6.
- ◆ Use keys 4-5 to select start reset "ON" / "OFF" and press 6 to confirm.
- ◆ Press 1 several times to exit the menu.

RESET

It allows you to bring all the values that can be changed by the user back to the factory settings.

CONTROLS PROCEDURE

- ◆ Press 6.
- ◆ Press 3 until **SETTINGS** appears and confirm by pressing 6.
- ◆ Keep pressing 3 until **STAND-BY** appears and confirm by pressing 6.
- ◆ Use keys 4-5 to enable "ON" / disable "OFF"
- ◆ Press 1 several times to confirm and exit the menu.

TO FIND OUT WHERE YOUR NEAREST SERVICE CENTRE IS, CONTACT YOUR DEALER OR GO TO THE WEBSITE:
WWW.LANORDICA-EXTRAFLAME.COM

CLEANING AND MAINTENANCE

ALWAYS FOLLOW THE INSTRUCTIONS IN COMPLETE SAFETY!

- ♦ Make sure that the power cord plug is disconnected as the generator may have been programmed to turn on.
- ♦ Make sure that all parts of the generator are cool.
- ♦ Make sure that the ashes are completely cold.
- ♦ Ensure sufficient air renewal in the room while cleaning the product.
- ♦ Poor cleaning will compromise correct operation and safety!

MAINTENANCE

For correct operation, the generator must undergo routine maintenance by a qualified technician, at least once a year. The periodic inspections and maintenance operations must always be performed by specialised, expert technicians who operate according to current legislation and following the instructions given in this use and maintenance manual.



ONCE A YEAR, HAVE THE SMOKE EXHAUST SYSTEM, SMOKE DUCTS AND T-SHAPED FITTINGS CLEANED, INCLUDING THE INSPECTION CAPS AND ANY ELBOWS AND HORIZONTAL SECTIONS! THE GENERATOR CLEANING FREQUENCY IS INDICATIVE! IT DEPENDS ON THE QUALITY OF THE PELLET USE AND ON HOW OFTEN IT IS USED. SOMETIMES THESE OPERATIONS MUST BE PERFORMED MORE OFTEN

PERIODICAL CLEANING BY THE USER

The periodic cleaning operations, as indicated in this use and maintenance manual, must be performed with the utmost care after reading the instructions, procedures and frequency described in this use and maintenance manual.

CLEANING THE SURFACES AND COATING

Never use abrasive or chemically aggressive detergents for cleaning!

The surfaces must be cleaned when the generator and coating are completely cold. For the maintenance of the surfaces and metal parts, simply use a cloth dampened with water or with water and neutral soap. Failure to comply with these instructions may damage the surfaces of the generator and result in the invalidation of the warranty.

CLEANING THE CERAMIC GLASS

Never use abrasive or chemically aggressive detergents for cleaning!

The ceramic glass must only be cleaned when the glass is completely cold. To clean the ceramic glass, simply use a dry brush and some damp newspaper dipped in ash. If the glass is very dirty, use a specific detergent for ceramic glass. Spray a small amount on a cloth and use it on the ceramic glass. Do not spray the cleaning agent or any other liquid directly on the glass or seals!

Failure to comply with these instructions may damage the surfaces of the ceramic glass and cause the invalidation of the warranty.

CLEANING THE PELLET HOPPER

When the hopper is completely empty, disconnect the generator power cord and remove the residues (dust, shavings, etc.) from the empty hopper before filling it.



THE SEALS OF THE PELLET HOPPER, BURN POT AND THE FIRE DOOR ENSURE THE CORRECT OPERATION OF THE STOVE. THEY MUST BE REGULARLY CHECKED BY THE USER AND IF THEY ARE FOUND TO BE WORN OR DAMAGED THEY MUST BE REPLACED IMMEDIATELY. THESE OPERATIONS MUST BE PERFORMED BY A QUALIFIED TECHNICIAN.



IF THE POWER CORD IS DAMAGED, IT MUST BE REPLACED BY THE AFTER-SALES SERVICE OR BY A SIMILARLY QUALIFIED PERSON, SO AS TO AVOID ALL RISKS.

BURN POT AND COMBUSTION CHAMBER:

- ◆ Vacuum the residues in the burn pot
- ◆ Remove the burn pot completely from its compartment;
- ◆ Vacuum the ash from the burn pot seat, glow plug tube and combustion chamber.
- ◆ Clear all the holes in the burn pot using the special tool supplied.
- ◆ Put the burn pot back in place and push it towards the back wall.

NOTE: Use a suitable vacuum cleaner with dedicated separation container for the ash collected.

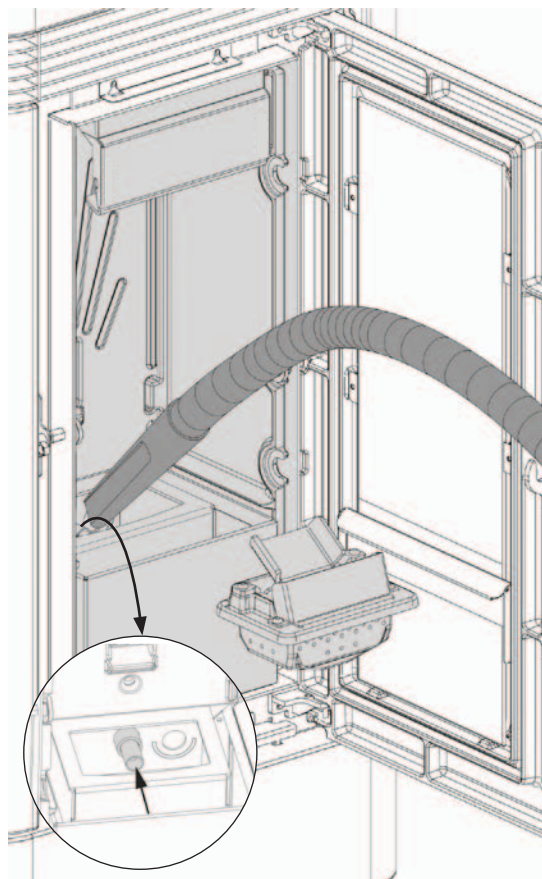

EXTRACTABLE ASH DRAWER:

- ◆ Remove the ash drawer and empty it into a suitable container.

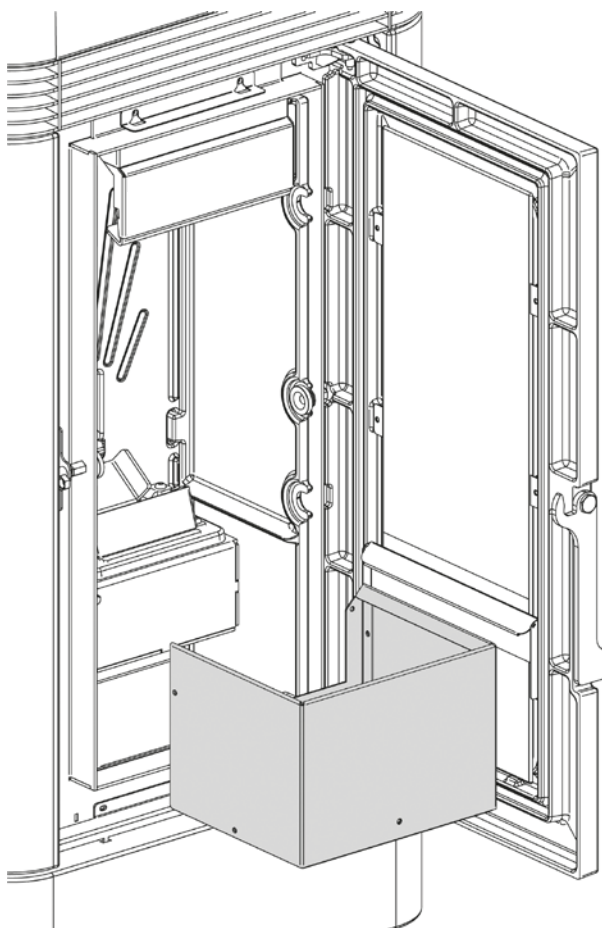

| PARTS/FREQUENCY | EVERY 2 DAYS | EVERY 7 DAYS | EVERY YEAR |
|------------------------------|--------------|--------------|------------|
| BURN POT | X | | |
| TUBE BUNDLE | | | X |
| COMBUSTION CHAMBER | X | | |
| EXTRACTABLE ASH DRAWER | | X | |
| T-SHAPED FITTING/ SMOKE DUCT | | | X |

A CLEAN BURN POT GUARANTEES CORRECT OPERATION!

BY MAKING SURE THE BURN POT AND ITS HOLES ARE ALWAYS CLEAN FROM ANY COMBUSTION RESIDUE, EXCELLENT COMBUSTION BY THE GENERATOR IS GUARANTEED OVER TIME, PREVENTING ANY MALFUNCTIONS THAT MAY REQUIRE THE INTERVENTION OF A TECHNICIAN.

THE "EASY SETUP" FUNCTION CAN BE USED TO ADAPT COMBUSTION ON THE BASIS OF THE NEEDS DESCRIBED.

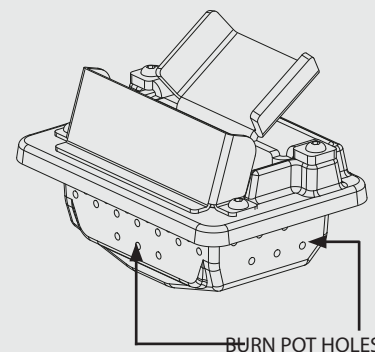

TO FIND OUT WHERE YOUR NEAREST SERVICE CENTRE IS, CONTACT YOUR DEALER OR GO TO THE WEBSITE:
WWW.LANORDICA-EXTRAFLAME.COM

ROUTINE MAINTENANCE PERFORMED BY QUALIFIED TECHNICIANS

Routine maintenance must be performed at least once a year.

Using pellets as solid fuel, the generator requires annual routine maintenance, which must be performed by a **qualified technician, using only original spare parts.**

Failure to comply with this may jeopardise the safety of the appliance and invalidate the warranty.

Respecting the cleaning frequencies reserved for the user described in the use and maintenance manual ensures correct combustion over time, avoiding any anomalies and/or malfunctions which may require more complex interventions by the technician. Requests for routine maintenance interventions are not included in the product warranty.

SEALS: PELLETT HOPPER LID, DOOR, ASH DRAWER AND BURN POT

The seals ensure that the stove is airtight and they guarantee the proper operation of the same.

They must be regularly checked: if they are found to be worn or damaged, they must be replaced immediately.

These operations must be performed by a qualified technician.

CONNECTION TO THE FLUE

Vacuum and clean the pipe that leads to the flue once a year or any time that it is necessary. If there are any horizontal sections, the residues must be removed before they obstruct the fumes passage.

PUTTING OUT OF SERVICE (END OF SEASON)

At the end of each season, before turning the stove off, it is advisable to empty the pellet hopper out completely and vacuum any pellet and dust residues.

It is also advisable to disconnect the generator from the electrical power supply and, for greater safety especially in the presence of children, remove the power cord.

Routine maintenance must be performed at least once a year.

TO FIND OUT WHERE YOUR NEAREST SERVICE CENTRE IS, CONTACT YOUR DEALER OR GO TO THE WEBSITE:
WWW.LANORDICA-EXTRAFLAME.COM

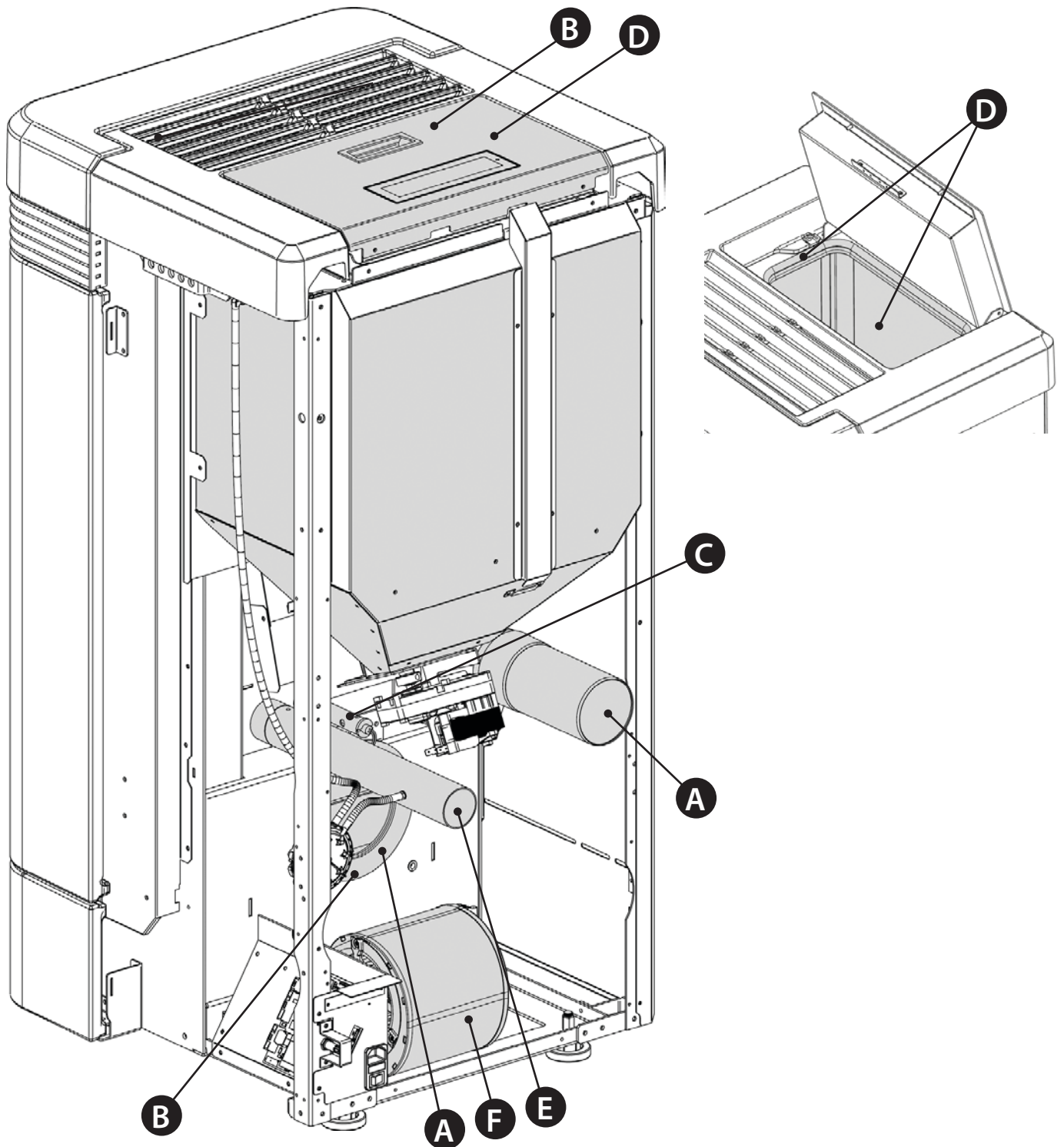

THE IMAGES ARE FOR ILLUSTRATIVE PURPOSES ONLY.

| | |
|----------|--|
| A | Fumes motor (disassembly and cleaning and fumes pipe and "T"), new silicone in the provided points |
| B | Seals, pallet hopper, inspections, ash drawer and door (replace and apply silicone where required) |
| C | Combustion chamber & exchanger (total cleaning) including cleaning the glow plug duct |
| D | Hopper (empty out completely and clean) and check seal. |
| E | Check air intake pipe and check/clean mechanical pressure switch |
| F | Room air fan disassembly and removal of dust and pellet debris. |

TO FIND OUT WHERE YOUR NEAREST SERVICE CENTRE IS, CONTACT YOUR DEALER OR GO TO THE WEBSITE:
WWW.LANORDICA-EXTRAFLAME.COM

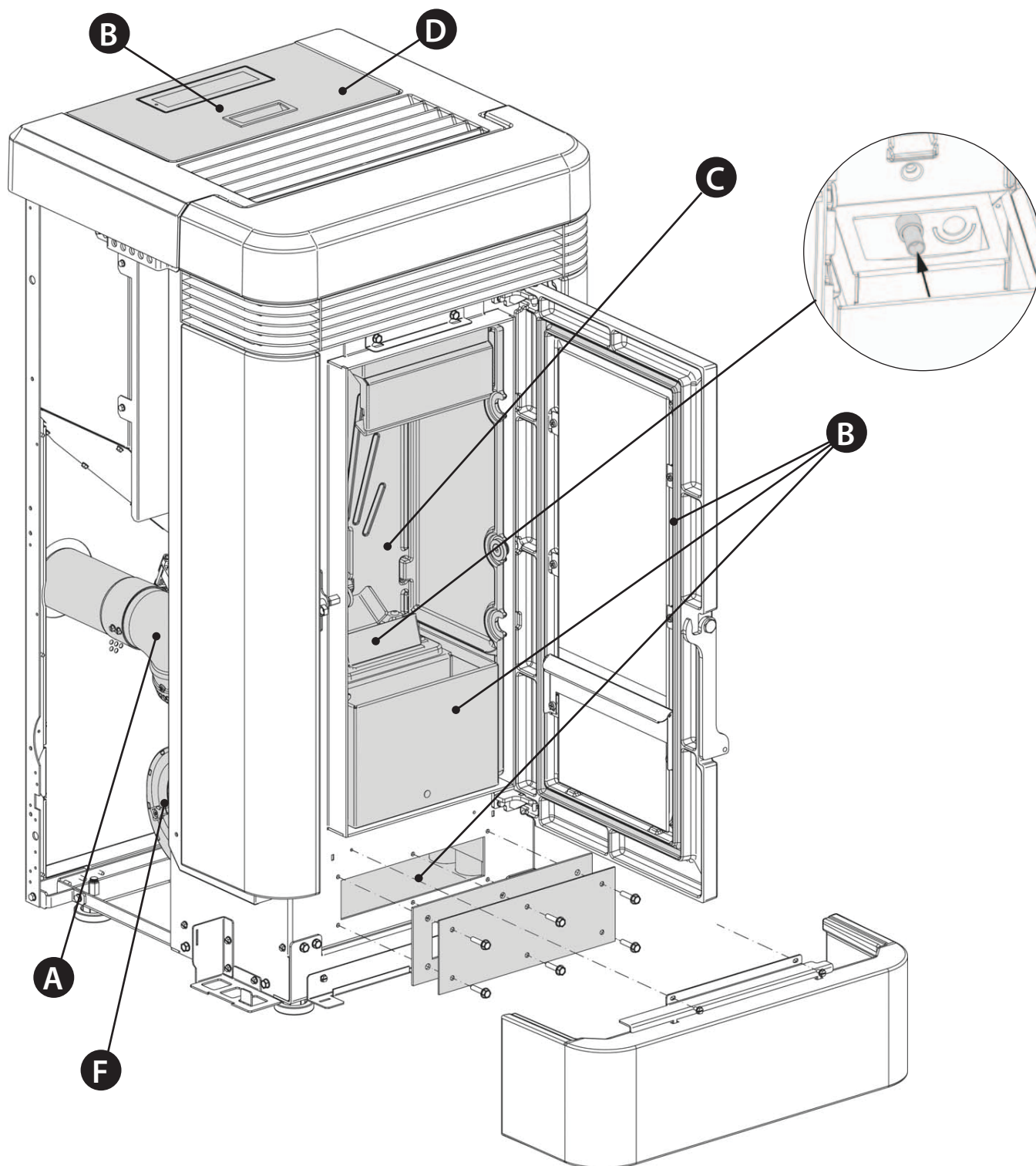

THE IMAGES ARE FOR ILLUSTRATIVE PURPOSES ONLY.

| | |
|----------|--|
| A | Fumes motor (disassembly and cleaning and fumes pipe and "T"), new silicone in the provided points |
| B | Seals, pallet hopper, inspections, ash drawer and door (replace and apply silicone where required) |
| C | Combustion chamber & exchanger (total cleaning) including cleaning the glow plug duct |
| D | Hopper (empty out completely and clean) and check seal. |
| E | Check air intake pipe and check/clean mechanical pressure switch |
| F | Room air fan disassembly and removal of dust and pellet debris. |

DISPLAYS

| DISPLAY | REASON |
|---------------------------|--|
| OFF | Generator off |
| START | The START phase is in progress |
| PELLET LOADING | Continuous pellet loading is in progress during the ignition phase |
| ON | The ignition phase is in progress |
| PREPARATION | The preparation phase is in progress |
| WORK | The normal work phase is in progress |
| MODULATION | The generator is operating at the minimum speed |
| FINAL CLEANING | The final cleaning is in progress |
| STAND-BY | Generator off waiting to turn back on due to the thermostat. |
| COOLING STAND BY | A new ignition is attempted when the generator has just be switched off. When the generator is switched off, it is necessary to wait for the fumes motor to switch off completely, then clean the burn pot. Only after performing these operations will it be possible to switch the generator on again. |
| BLACK OUT STAND BY | The generator is cooling down after a power failure. After the cooling phase, it will turn back on automatically |
| BLOW | The automatic blow is active |
| CLOSE HOPPER - STOVE DOOR | This indication means that you have 60 seconds to close the hatch/door and the pellet lid. Once 60 seconds have passed, during ignition the stove will go into "DEPR ALARM" mode, while during normal operation the stove will go into "COOLING STAND-BY" mode before automatically restarting when the conditions are satisfied (cold stove, etc.). |

ALARMS

| DISPLAY | EXPLANATION | SOLUTION |
|---|---|--|
|  | Indicates the presence of an alarm. | On: indicates the presence of an alarm The alarm can be reset only if the fumes motor has stopped and 15 minutes have passed since the alarm was displayed, by pressing key 1 for 3 seconds. |
| FUMES MOTOR FAULT | Fumes motor failure | Contact the service centre |
| FUMES PROBE | Fumes probe fault. | Contact the service centre |
| HOT FUMES | High exhaust temperature | Check pellet loading (see "Easy setup"); if the problem is not solved, contact a qualified technician. |
| NO IGNITION | The pellet hopper is empty. Unsuitable pellet loading calibration. Thermostat bulbs tripped. | Check for the presence of pellets in the hopper. Adjust the pellet flow (see "Easy setup"). Check the procedures described in the "Ignition" chapter. Check the thermostats with bulbs (see chapter on Resetting) |
| NO FLAME | The pellet hopper is empty. Pellets not loading. The gear motor is not loading pellets. | Check for the presence of pellets in the hopper. Adjust the pellet flow (see "Easy setup"). |
| DEPR ALARM | The door is not closed properly. The ash drawer is not closed properly. The combustion chamber is dirty. The fumes exhaust pipe is blocked/dirty | Check that the door closes hermetically. Check that the ash drawer closes hermetically. Make sure that the fumes pipe and the combustion chamber are clean. |
| NO IGNITION - BLACK OUT | No power during the ignition phase. | Turn the stove off by pressing key 1 and repeat the procedures described in the "Ignition" chapter. Other restoration operations must be performed by an authorised technician. |
| ALARM COMMAND AUGER | Abnormal operation of pellet loading. | Contact the service centre |

GUARANTEE TERMS

1. EXTRAFLAME S.p.A. products are guaranteed, within the European community, for 24 months from the date of purchase. Purchase has to be proved by means of a valid fiscal document issued by the seller (receipt, invoice or shipment document) identifying the purchased product and its purchase and/or delivery date.

WARNING: *This conventional guarantee does not replace the guarantee regulated by the European legislation on consumer rights.*

The conventional guarantee is only applicable to the Italian region and to those areas, within the European Community, where the Authorised Technical Assistance Centres are active (see the www.lanordica-extraflame.com website)

It is also limited to the state of residence of the consumer, which must coincide with the premises and/or registered office of the seller of the EXTRAFLAME S.p.A. product

These regulations do not apply if the product is purchased within commercial, entrepreneurial, or professional circumstances. In these cases the product guarantee will be limited to a period of 12 months from the date of purchase.

ITALIAN GUARANTEE

What must be done if there is a product malfunction:

Consult the instructions manual to make sure the malfunction cannot be solved by using the product correctly. Make sure the malfunction is included in those covered by the guarantee; otherwise the cost of the intervention will be borne entirely by the consumer. When requesting the intervention of the Assistance service at the Authorised Assistance Centre, always specify: - type of malfunction - model of the appliance - complete address - phone number

EUROPEAN GUARANTEE

What must be done if there is a product malfunction:

Consult the instructions manual to make sure the malfunction cannot be solved by using the product correctly. Make sure the malfunction is included in those covered by the guarantee; otherwise the cost of the intervention will be borne entirely by the consumer. Request the intervention of the Assistance service or the address of the Authorised Technical Assistance Centre to the seller; always specify: type of malfunction, model of the appliance, complete address and phone number

If the malfunction arises in the first 6 months of the product's life, the consumer has the right to have the product repaired with no expense. From the seventh to the twenty-fourth month, if a malfunction arises, the consumer will bear the cost of the call, while the seller will pay for the manpower and for any spare parts used.

2. If the malfunction is linked to external events and/or conditions such as, including but not limited to, insufficient capacity of the systems; wrong installation and/or maintenance by the personnel which hasn't got the skills prescribed by the laws of the country of residence of the consumer; negligence; inability to use the product and wrong maintenance by the consumer, with respect to what is reported and recommended by the instructions manual of the product, which is part of the sales contract, this guarantee will be void.

Damage to the product that cannot be related to manufacturing defects are also not included in this guarantee. Similarly are excluded defects related to incorrect operation of the flue, according to the legislation in force in the country at the moment of purchase. Other exclusions include all product defects due to carelessness, accidental breakdown, tampering and/or damage during transport (scratches, dents, etc.), interventions carried out by unauthorised personnel and further damage caused by incorrect interventions by the consumer trying to arrange the initial malfunction.

The following consumables are excluded by the guarantee: gaskets, ceramic or tempered glasses, cast iron grilles or coatings, refractory materials (e.g. Nordiker or others), painted, chrome-plated or golden parts, majolica ware, handles, the brazier and its related components. For Idro products the heat exchanger is not covered by the guarantee if a suitable condensation-proof circuit is not set up to ensure a return temperature of the device of at least 55°C. The guarantee excludes all the external components on which the consumer can directly operate during use and/or maintenance or that can be subject to wear and/or rust and stains on steel due to aggressive detergents.

If malfunctions are signalled which are not later confirmed during check by an authorised technician, the cost of the intervention will be borne entirely by the consumer.

3. If it is not possible to restore product conformity by repairing it, the product/component will be replaced, the guarantee expiration date and conditions will remain the same established when the product/component to be replaced has been purchased.

4. EXTRAFLAME S.p.A. cannot be held liable for injury or damage which may - either directly or indirectly - be caused to persons, animals and property ensuing from failure to observe all the instructions provided in the relevant instruction manual and the warnings regarding installation, use and maintenance of the product, that can also be downloaded on the website.

5. Interventions for adjusting and/or regulating the product for the type of fuel or other reasons are excluded by the guarantee.

6. If the product is repaired in one of the Authorised Technical Assistance Centres indicated by EXTRAFLAME S.p.A. and if the product is replaced, transport will be free of charge. If the technician can repair the product at the user's place of residence and they refuse, transport to the workshop and redelivery will be paid by the consumer.

7. After the 24 months of the guarantee have elapsed any repair intervention cost will be completely borne by the consumer.

8. In the case of disputes the only competent court is that of the EXTRAFLAME S.p.A. registered office - (Vicenza-Italy)

ADDITIONAL WARNINGS

- ◆ Only use the fuel recommended by the manufacturer. The product must not be used as an incinerator.
- ◆ Do not use the product as a ladder or supporting structure.
- ◆ Do not place laundry on the product to dry it. Any clothes-horse or similar objects must be kept at due distance from the product. Danger of fire or damage to the coating.
- ◆ The user is fully liable for any incorrect use of the product. The manufacturer bears no civil or criminal liability for incorrect use.
- ◆ Unauthorised tampering of any nature or replacement of spare parts of the product with non-original parts may endanger the operator and the manufacturer bears no civil or criminal liability for this.
- ◆ Large parts of the surface of the product can get very hot (door, handle, glass, smoke outlet pipes, etc.). Please therefore avoid coming into contact with these parts without wearing suitable protective clothing or using appropriate measures, such as heat protective gloves.
- ◆ DO NOT use the product with the door open or if the glass is broken.
- ◆ The product must be electrically connected to a system equipped with an operational earthing system.
- ◆ Turn off the product in the event of a failure or malfunctioning.
- ◆ Unburned pellets that build up in the burner following each failed start-up must be removed before attempting to start up the product again. Make sure that the burner is clean and correctly positioned before starting it up again.
- ◆ Do not wash the product with water. Water may penetrate into the unit and cause faults in the electrical insulation. This can cause electric shocks.
- ◆ Installations not complying with the regulations in force, as well as incorrect use and failure to comply with the maintenance scheduled by the manufacturer, will invalidate the guarantee.

DISPOSAL

INFORMATION FOR MANAGEMENT OF ELECTRIC AND ELECTRONIC APPLIANCE WASTE CONTAINING BATTERIES OR ACCUMULATORS



This symbol, which is used on the product, batteries, accumulators or on the packaging or documents, means that at the end of its useful life, this product, the batteries and the accumulators included must not be collected, recycled or disposed of together with domestic waste. Improper management of electric or electronic waste or batteries or accumulators can lead to the leakage of hazardous substances contained in the product. For the purpose of preventing damage to health or the environment, users are kindly asked to separate this equipment and/or batteries or accumulators included from other types of waste and to arrange for disposal by the municipal waste service. It is possible to ask your local dealer to collect the waste electric or electronic appliance under the conditions and following the methods provided by national laws transposing the Directive 2012/19/EU.

Separate waste collection and recycling of unused electric and electronic equipment, batteries and accumulators helps to save natural resources and to guarantee that this waste is processed in a manner that is safe for health and the environment.

For more information about how to collect electric and electronic equipment and appliances, batteries and accumulators, please contact your local Council or Public Authority competent to issue the relevant permits.

Extraflame®

Riscaldamento a Pellet

EXTRAFLAME S.p.A. Via Dell'Artigianato, 12 36030 - MONTECCHIO PRECALCINO (VI) - ITALY
☎ +39.0445.865911 - 📠 +39.0445.865912 - ✉ info@extraflame.it - 🌐 www.lanordica-extraflame.com

MADE IN ITALY
design & production

*TO FIND THE SERVICE CENTRE NEAREST TO YOU
CONTACT YOUR DEALER OR CONSULT
THE SITE WWW.LANORDICA-EXTRAFLAME.COM*

The manufacturer reserves the right to vary the characteristics and the data reported in this pamphlet at any moment and without notice, in order to improve its products.
This manual, therefore, cannot be regarded as a contract towards other parties.