

Lina TV 45 h/s

Data sheet

Details

- Fireplace insert as tunnel version
- 4545 – Height 45 cm
4551 – Height 51 cm
4557 – Height 57 cm
- Self-closing door
- Standard fire box inner lining: white smooth chamotte
- High-grade cast-iron dome, all parts can be moved, adjustable between 0 – 90°
- Overall height can be simply and quickly adjusted
- Easy to dismantle for transport



Lina TV 45 with guillotine front side and hinged rear side

Technical data

• Nominal heat output	7 kW
• Thermal output range	3,4 – 7,8 kW
• Efficiency	>78 %
• Insulation thickness (with wall that does not need to be protected) (based on SILCA® 250KM)	60 mm
• Combustion air connector	Ø 125 mm
• Recommend length of logs	33 cm
• Weight	210 – 230 kg
• Heat distribution through the viewing window	50 %
• Heat distribution, convective output	50 %

Data for chimney sweep according to DIN EN 13384 (Closed operation)

Triple values with nominal heat output

• Flue gas mass flow	7,5 g/s
• Flue gas temperature	330 °C
• Required delivery pressure	12 Pa

Triple values for calculating ceramic flues (wood fuel)

• Firing power	18,2 kW
• Flue gas mass flow	14,7 g/s
• Flue gas temperature upstream of the connecting surface	337 °C
• Required delivery pressure at the flue gas connector	15 Pa
• Combustion air requirement	63,9 m³/h
• Recommended flue length ¹	3,5 m

Data for closed design

• Minimum heat-emitting surface ²	2,4 m ²
--	--------------------

¹The information regarding flue lengths is a recommendation and based on the calculation in accordance with TROL 2022 chapter 15. The calculation is based on a medium-heavy design and a flue ratio of 360 cm².

²Average value based on the storage time. Dependent on the material properties and the construction thickness. Mean specific heat distribution = approx. 500 W/m²

There may be modifications to the colour and technical details caused by ongoing developments; subject to errors and omissions. Dated: 01/2024

Standard



Tunnel version



Kristall front



Guillotine door (rear side hinged door on left)



Guillotine door (rear side hinged door on right)



125 mm
Combustion air connector

Optional



Double glazing



150 mm
Combustion air connector

Accessories



SMR



Hot water top-mounted element R



Energy efficiency class in accordance with (EU) 2015/1186



1. Federal Emissions Control Ordinance Stage 2



Lina TV 45 h/s

Dimensional drawing

Front view, scale 1:20

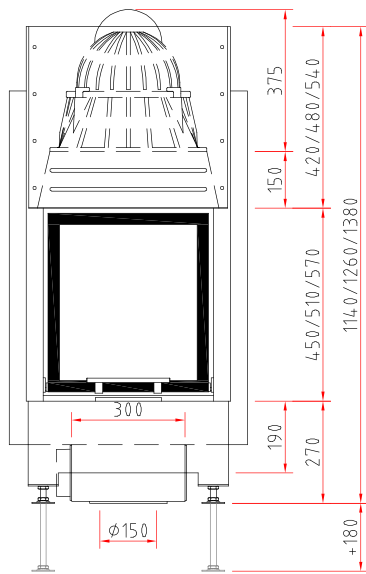

Side view, scale 1:20

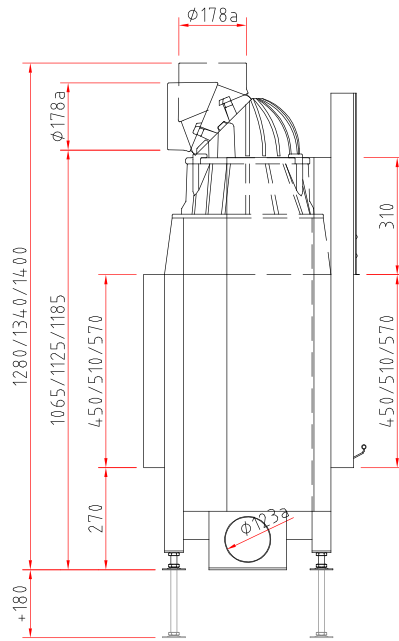

Top view, scale 1:10

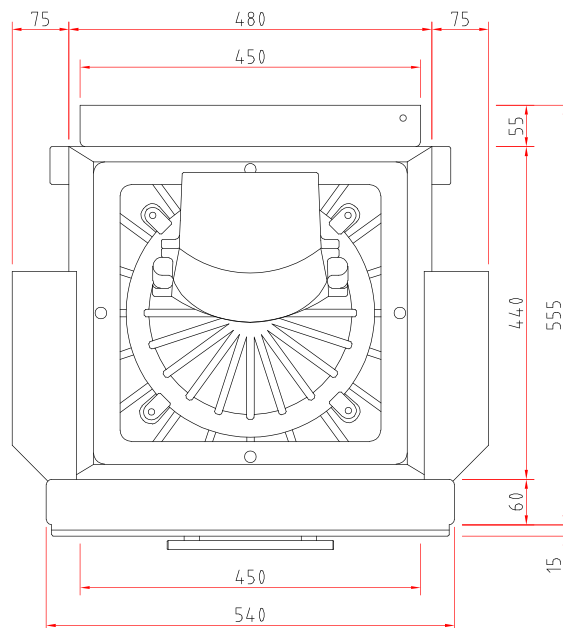

Product data sheet

Regulation (EU) 2015/1186 supplementing Directive 2010/30/EU

	Lina 45 s/h, Lina TV 45 s/h
Supplier's name:	Camina & Schmid Feuerdesign und Technik GmbH & Co. KG
Supplier's model identifier:	Lina 45 s/h, Lina TV 45 s/h
Energy efficiency class:	A
Direct heat output (kW)	7,0
Indirect heat output (kW):	-
Energy efficiency index (EEI):	103,7
Energy efficiency at nominal heat output (%):	78,4
Notes for specific precautions, installation or maintenance:	Please note the reference in the assembly instructions and operating manuals!

There may be modifications to technical details caused by ongoing developments; subject to errors and omissions. Dated: 11/2021



ENERG
енергия · ενέργεια



Camina  Schmid Lina 45 s/h, Lina TV 45 s/h

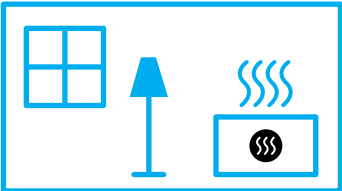

7,0
kW

ENERGIA · ЕНЕРГИЯ · ΕΝΕΡΓΕΙΑ · ENERGIJA · ENERGY · ENERGIE · ENERGI

2015/1186