

EN Installation manual

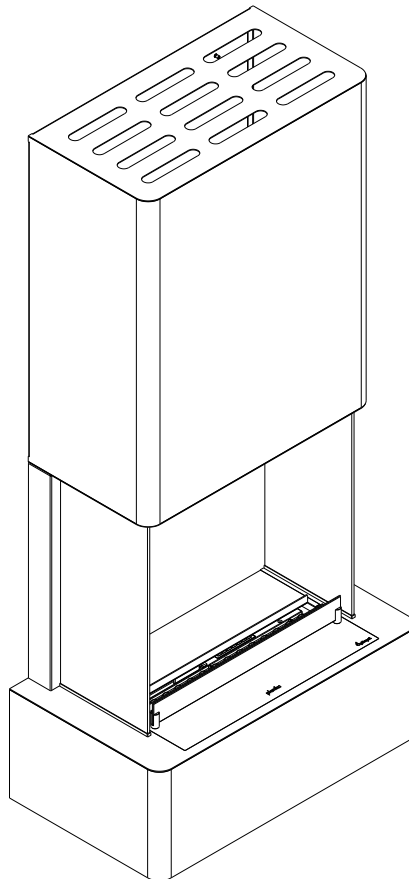

WARNING / WARNUNG / ADVERTENCIA / AVERTISSEMENT / ATTENZIONE / OSTRZEŻENIE / ВНИМАНИЕ

EN This Manual only applies to the installation of Aura only. The operation of the device and additional ceramic logs assemble is included in the dedicated manuals.

This product complies with all the required Product Safety, Electromagnetic Compatibility and Environmental Standards. This product is fully compliant with the LVD, EMC, RoHS and Eco Design Directives.

TABLE OF CONTENTS

1. IMPORTANT INFORMATION	3
2. GENERAL INFORMATION	4
3. WATER QUALITY & CLEANING.....	5
4. INSTALLATION INSTRUCTIONS	5
5. COMMISSIONING/INITIAL PRODUCT START-UP	5
8. OPERATING THE PRODUCT	6
9. MANUAL & REMOTE CONTROL OPTIONS	7
10. FLAME CONNECT APP	7
11. MAINTENANCE	14
12. TROUBLESHOOTING	15
13. ADDITIONAL INFORMATION	15
14. PATENT / PATENT APPLICATION	16
15. APPENDIX	16

1. IMPORTANT INFORMATION

This product is only suitable for well insulated rooms or occasional use.

Please read this information guide carefully to be able to safely install, use and maintain your product.

Failure to follow these instructions may cause injury and/or damage and may invalidate your guarantee.

When using electrical appliances, basic precautions should always be followed to reduce the risk of fire, electrical shock and injury to persons, including the following:

- If the appliance is damaged, check with the supplier before installation and operation.
- Do not use this appliance if it has been dropped.
- Do not use outdoors.
- Do not use in the immediate surroundings of a bath, shower or swimming pool.
- Do not locate the appliance immediately below a fixed socket outlet or connection box.
- Do not use this appliance in series with a thermal control, a program controller, a timer or any other device that switches on the heat automatically, since a fire risk exists when the heater is accidentally covered or displaced.
- Use this appliance on a horizontal and stable surface.

This appliance can be used by children aged from 8 years and above and persons with reduced physical, sensory or mental capabilities or lack of experience and knowledge if they have been given supervision or instruction concerning use of the appliance in a safe way and understand the hazards involved. Children shall not play with the appliance. Cleaning and user maintenance shall not be made by children without supervision.

Children aged from 3 years and less than 8 years shall only switch on/off the appliance provided that it has been placed or installed in its intended normal operating position and they have been given supervision or instruction concerning use of the appliance in a safe way and understand the hazards involved. Children aged from 3 years and less than 8 years shall not plug in, regulate and clean the appliance or perform user maintenance.

Children of less than 3 years should be kept away unless continuously supervised.

CAUTION: Some parts of this product can become very hot and cause burns. Particular attention has to be given where children and vulnerable people are present.

Although this appliance complies with safety standards, we do not recommend its use on deep pile carpets or on long hair type of rugs. Ensure that furniture, curtains or other combustible material are positioned no closer than 1 meter from the appliance.

The appliance must be positioned so that the plug is accessible. In the event of a fault unplug the appliance. Unplug the appliance when not required for long periods.

If the supply cord is damaged it must be replaced by the manufacturer or service agent or a similarly qualified person in order to avoid a hazard. Keep the supply cord away from the front of the appliance.

WARNING: This appliance must be earthed.

WARNING: In order to avoid overheating, do not cover the appliance. Do not place material or garments on the appliance, or obstruct the circulation around the appliance.



The appliance carries a DO NOT COVER warning symbol.

WARNING: Risk of fire - We do not recommend the use of this appliance connected through an extension lead or any external switching device such as a plug in timer or remote control plug in adaptor. All heating appliances draw high current through the mains supply and any weakness in the design, connections or components in these devices can easily result in overheating of the connection points resulting in melting, distortion and even the risk of fire!

WARNING: This appliance is not equipped with a device to control the room temperature. Do not use this appliance in small rooms when they are occupied by persons not capable of leaving the room on their own, unless constant supervision is provided.

WARNING: KEEP BATTERIES OUT OF REACH OF CHILDREN

1. Swallowing may lead to serious injury in as little as 2 hours or death, due to chemical burns and potential perforation of the oesophagus.
2. If you think batteries might have been swallowed or placed inside any part of the body seek immediate medical attention
3. Examine devices and make sure the battery compartment is correctly secured, e.g. that the screw or other mechanical fastener is tightened. Do not use if the compartment is not secure.
4. Dispose of used button batteries immediately and safely. Flat batteries can still be dangerous.

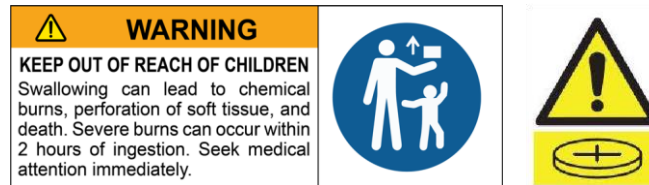

CAUTION: No obvious symptoms

Unfortunately, it is not obvious when a button or coin battery is stuck in a child's oesophagus (food pipe). There are no specific symptoms associated with this. The child might:

- cough, gag or drool a lot;
- appear to have a stomach upset or a virus;
- be sick;
- point to their throat or stomach;
- have a pain in their abdomen, chest or throat;
- be tired or lethargic;
- be quieter or more clingy than usual or otherwise "not themselves";
- lose their appetite or have a reduced appetite; and
- does not want to eat solid food/be unable to eat solid food.

These sorts of symptoms vary or fluctuate, with the pain increasing and then subsiding.

A specific symptom to button and coin battery ingestion is vomiting fresh (bright red) blood. If the child does this seek immediate medical help.

The lack of clear symptoms is why it is important to be vigilant with "flat" or spare button or coin batteries in the home and the products that contain them.

2. GENERAL INFORMATION

Unpack the appliance carefully and retain the packaging for possible future use, in the event of moving or returning the fire to your supplier.

The appliance is a flame effect only. The appliance is designed to be built into a surround or built into a wall.

Please note: Used in an environment where background noise is very low, it may be possible to hear a sound which is related to the operation of the flame effect. This is normal and should not be a cause for concern.

This product contains and utilises water as an aspect of its operation, the adherence to the cleaning requirement as detailed within the instructions is necessary to ensure that risk/s through bacterial proliferation are minimised. Please refer to the Maintenance section in the following instruction booklet for details on the cleaning.

Once installed, never move this appliance or lay on its back, without draining the water from sump and water tank.

3. WATER QUALITY & CLEANING

Normal clean tap water (filtered) should be used in this device. In areas with hard water, a water softener (decalcifier) is recommended and more frequent cleaning and maintenance may be required.

Unfiltered water supplied from a well or another unmonitored supply is not recommended. The water tank, sump, sump lid, tank cap and air filters must be cleaned once every week, particularly in hard water areas. This is to remove dirt and prevent build up of limescale which could damage the product.

If you intend not using the appliance for longer than a week, drain the water from sump and water tank and dry the sump.

Ensure any soap/cleaning detergents if used are rinsed off fully to remove any residue before reusing parts. Do not use any harsh or corrosive chemicals for cleaning as these could damage the parts.

The sump and the water tank in this product are treated with a biocidal product, Silver Biocide. This conforms to the latest relevant ISO standard.

Do not drink the water from the sump or from the water tank(s).

4. INSTALLATION INSTRUCTIONS

This section describes how to install and set up your fire. Before you start:

- Ensure that all packing items are removed (read any warning labels carefully) and retain all packing for possible future use.
- Before connecting the appliance, check that the supply voltage is the same as that stated on the appliance.

ASSEMBLING THE PRODUCT

- Product size is shown on (Fig.1).
- Place the middle element and the side glasses in the dedicated profiles. Connect the middle section with bottom one using screws. Assemble the adjustable legs (Fig.2)
- Assemble the glass profile to the upper part and connect it using screws and washers. Place the upper element on the top of the middle section and glasses. Connect it using screws (Fig.3)

VENTILATION

This product needs free ventilation from underneath to operate correctly. There are slots on the underside of the product to allow this free air through the product. The free ventilation helps keep the electronic components cool and allows the mist to rise and leave the product.

ELECTRICAL CONNECTION

Plug the product into a 16amp 230/240 Volt outlet. Be sure to have access to the plug after installation to allow for disconnection. Ensure that the supply cable exits at the back of the fire at the right or left hand corner to suit your supply socket location and is not trapped under the fire such that it might cause it to be damaged.

GLASS ASSEMBLING

Set the glass shield on the top plate of the product leaving 20mm from the steam rail (Fig 4)

5. COMMISSIONING/INITIAL PRODUCT START-UP

CONNECTING THE RECEIVER/TETHERED REMOTE

With the top plate removed, Connect the Bluetooth receiver connector into the receiver cable socket at the back of the appliance (Fig 5). It is important to ensure that the jack is pushed fully into the socket. Failure to fully insert the connector will prevent the product from functioning correctly. The receiver has a cable length of 1.4m which will allow you position it anywhere around the product. If you prefer to hide it, the receiver can be placed inside the surround/wall. Please ensure that the receiver is not enclosed in metal, concrete or any other dense material, this will affect the signal from the remote control.

FILLING THE WATER TANK

Before powering on the product for the first time, ensure that a full water tank has been placed on the product. Remove the water tank from its location on top of the sump (Fig 6) and open it by unscrewing the orange cap (Fig 7). The tank should be filled with clean (decalcified) water only - Refer to WATER QUALITY & CLEANING for more details. When the tank is replaced on top of the sump, it will take about one minute for the tank to empty into the sump. Allow the sump to fill fully before switching on the product. Once filling is complete, the tank can be refilled and replaced on top of the sump. This will allow for the maximum capacity of water to be stored in the product.

8. OPERATING THE PRODUCT

This section describes how to activate your fire using either the manual controls or remote control.

MAINS SWITCH

The mains switch is located under the top plate on the module and controls the electricity to the appliance (Fig 8A). Note: This switch must be in the 'ON' (I) position for each appliance to operate.

MANUAL CONTROLS

Manual controls are located on the cassette module under the top plate. There are also manual controls on the tethered receiver unit which is fitted loose.



REMOTE CONTROL

The remote control is supplied with 2x CR2032 batteries already fitted. Pull both tabs from the rear cover to engage the batteries (Fig 9) and allow remote operation.

Note: The tethered receiver must be fitted to the product for remote control operation.

PAIRING THE REMOTE CONTROL

The remote control has wireless Bluetooth technology and needs to be paired to the receiver. This can be done by following the steps below.

1. Press the rocker switch to the on (I) position.
2. Press the  button on the Button Panel; the product will turn on.
3. Press the  button on the Button Panel, the LED's will start to slowly blink on and off.
4. Press the  button on the remote control; the product LEDs will flash quickly five times and the product will then automatically switch off. The remote control is now paired to the product and can be used to switch it back on.

TO REPLACE THE BATTERIES

1. Remove battery cover of the remote control using a Philips screwdriver (Fig 9).
2. Correctly install two 3 Volt (CR2032 or similar) battery in the battery holder with the + side facing up .
3. Secure the battery cover using the previously removed screw.





Batteries must be recycled or disposed of properly.

Check with your Local Authority or Retailer for recycling advice in your area .

Frequency band(s) this product operates in: 2.4GHz

Maximum radio-frequency power transmitter in the frequency band(s) this product operates in: 2.71dBm

GETTING THE DESIRED FLAME EFFECT

1. Switch the appliance on by pressing the main switch to the on position and pressing the  button. The flames will start after 45seconds.
2. Press the  and  buttons to adjust the flame to your desired level. Please give the flame generator time to react to the changes you make.









Once you have made your adjustments to both the flame height and crackling sound, the appliance will keep these settings even if you power off the appliance by either the on/standby button or by the main switch. The next time you switch on the appliance, it will start up as normal, wait 45 seconds for the flames to start and then revert to the adjusted settings.

SETTING THE HOME PERFUME KIT (optionally)

1. Slide in the fiber material into perfume pocket. (Fig 17).
2. Set few drops on the material (Fig 17).
3. Assemble the perfume pocket on the device rail (Fig 17).

NOTE: Avoid contact with eyes. Do not use orally or undiluted directly on the skin. Store in a tightly closed bottle at room temperature away from heat and light, out of the reach of children. Nursing and pregnant women should consult an aromatherapist before use. For external use only. The oil should be diluted before use.

9. MANUAL & REMOTE CONTROL OPTIONS

	Standby	Press to turn on the unit or to put it into standby mode. There is a brief delay after pressing this button before the unit turns on. Note: When the unit is turned on there is a 45 second warm up sequence before the flame effect starts.
	Increase Flame effect	Press repeatedly (or press and hold) to increase flame intensity. The unit will emit an audible beep when max level reached.
	Decrease Flame effect	Press repeatedly (or press and hold) to decrease flame intensity. The unit will emit an audible beep when min level reached.
	Flame effect Theme	Press repeatedly to cycle through the different Flame themes below: 1 - Natural Flame 2 - Blue 3 - Violet 4 - Red 5 - Aquamarine 6 - Prism Mode - the flames will cycle through the different colours.
	Increase Volume (Remote)	Press repeatedly (or press and hold) to increase the volume level of the crackling sound effect.
	Decrease Volume (Remote)	Press repeatedly (or press and hold) to decrease the volume level of the crackling sound effect.
	Brightness	Press repeatedly to cycle the top light brightness settings: B1 - Brightness level 1 B2 - Brightness level 2 B3 - Brightness level 3 B4 - Brightness level 4 B5 - Brightness level 5 B6 - Pulsating effect
	Timer	Press repeatedly to set the duration of the timer. The fireplace goes into standby after the time has elapsed. The timer can be set for 1 hour (1 presses), 2 hour (2 presses) and Timer OFF (3 presses).

10. FLAME CONNECT APP

The fireplace is capable of being controlled using the Flame Connect App for mobile devices. This is available to download to your device from Google Play or Apple App stores. Follow the on screen instructions for set-up.

NOTE: The fireplace will not operate using the provided remote control when the app is open on a mobile device.

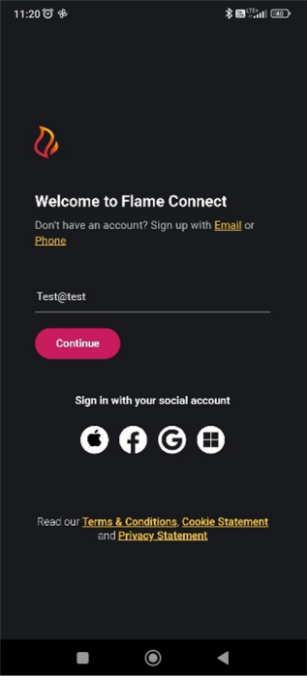
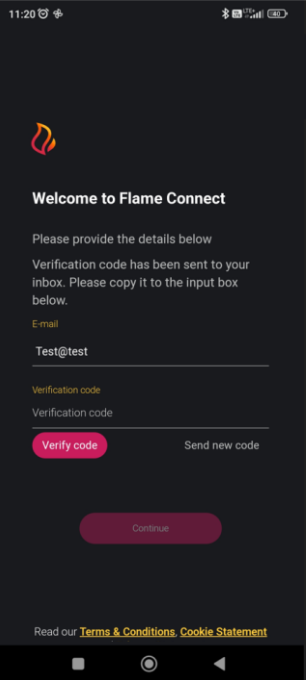
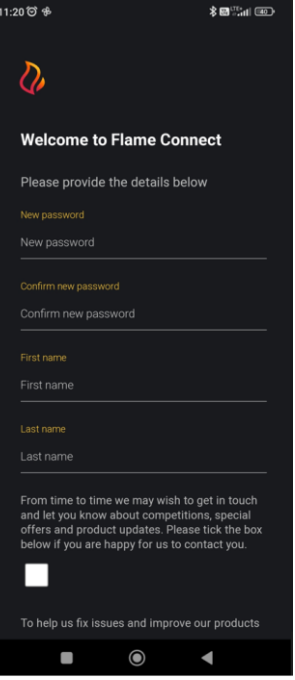
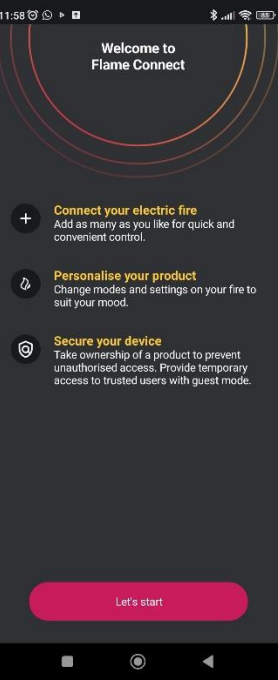

PAIRING THE DEVICE

Sign in or create account	Verification code	Form	Starting
			
Sign in or create account by email or phone	Click on "send verification code" and set it in	Fill in the form and continue	Click on "lets start" to start pairing the device

PAIRING THE DEVICE

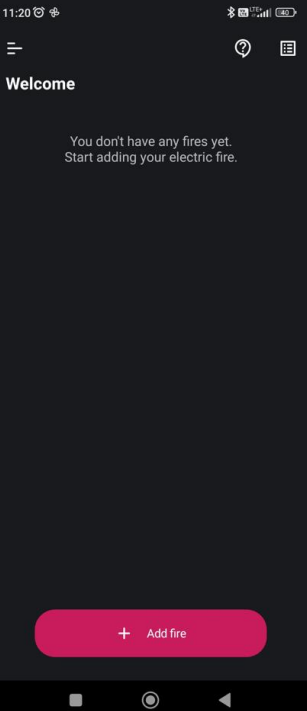
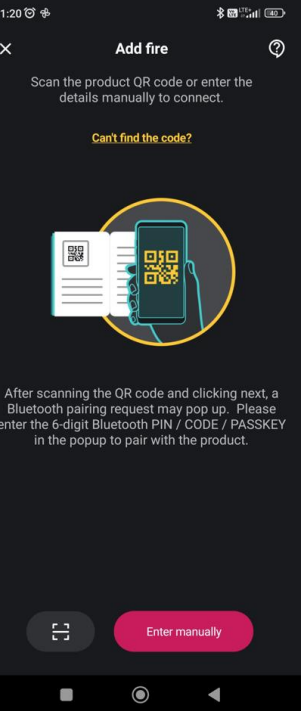
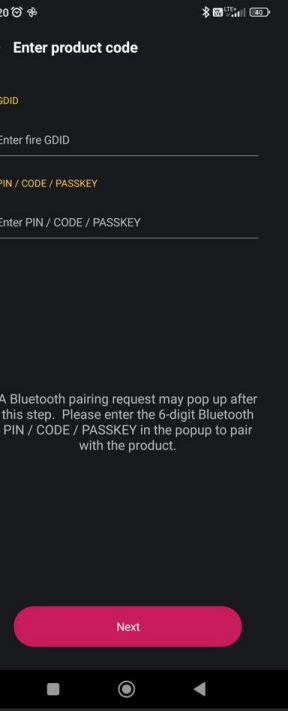
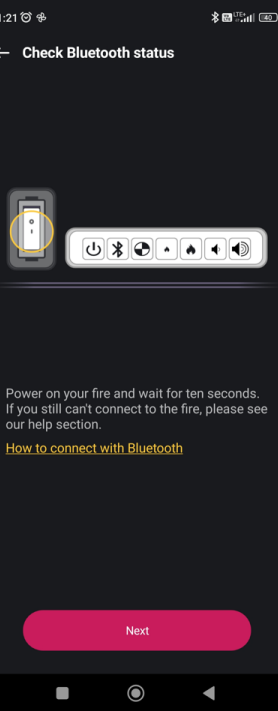
Adding the device	Code and PIN	Entering the code	Check Bluetooth
			
Click on "add fire" to add device	Click on "scan icon" to scan the QR code of the device or click "enter manually" to write the code	Pass the GDID and PIN located under the top plate of the device. Click next.	Make sure that Bluetooth on mobile device is ON

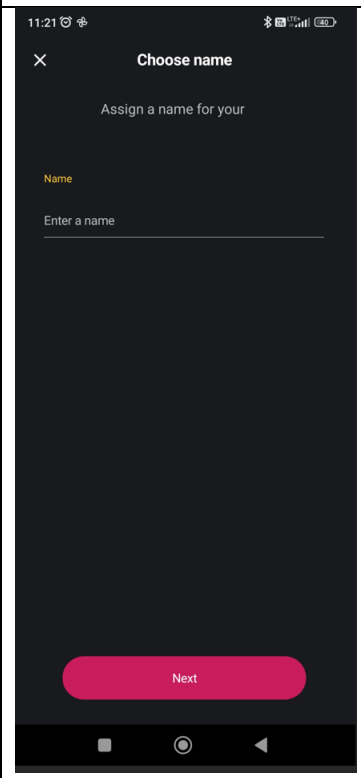
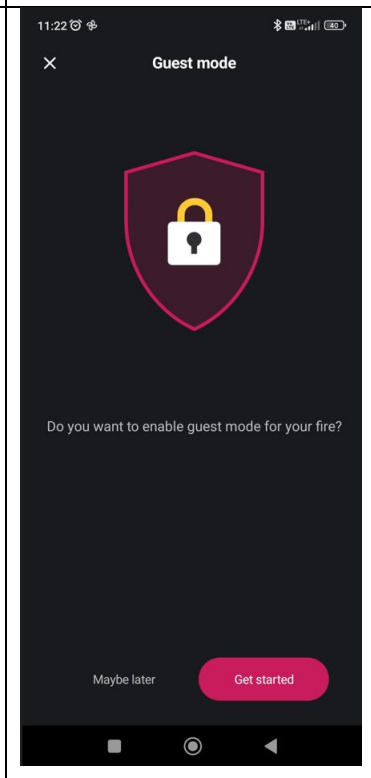
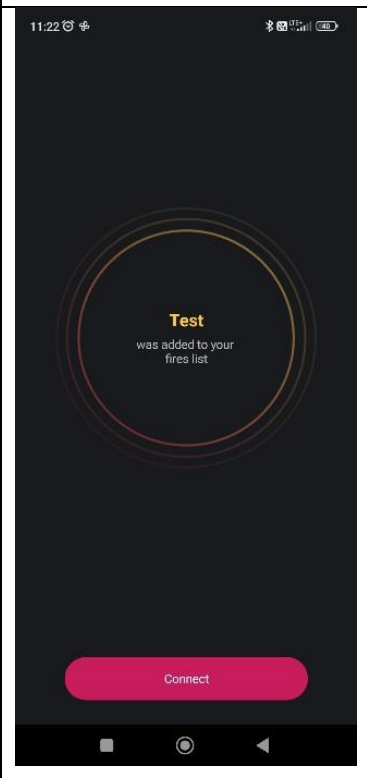
Device name	Guest mode	Connect	
			
<p>Assign a name for your device and click next</p>	<p>Set guest mode by clicking on "Get Started" or skip by "Maybe later"</p>	<p>Click on "connect"</p>	

TURNING ON / OFF DEVICE

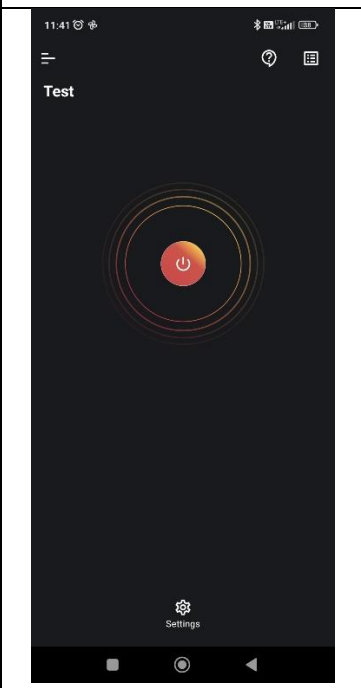
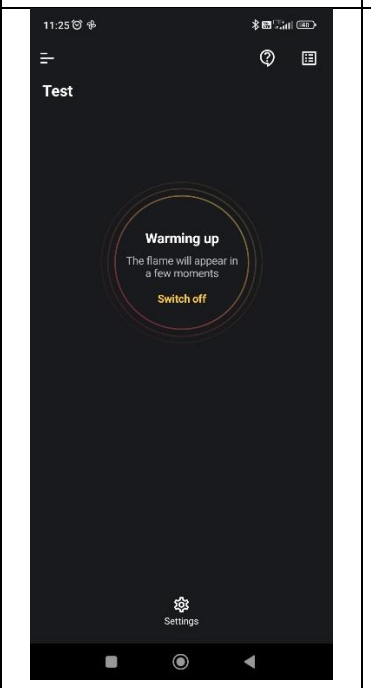
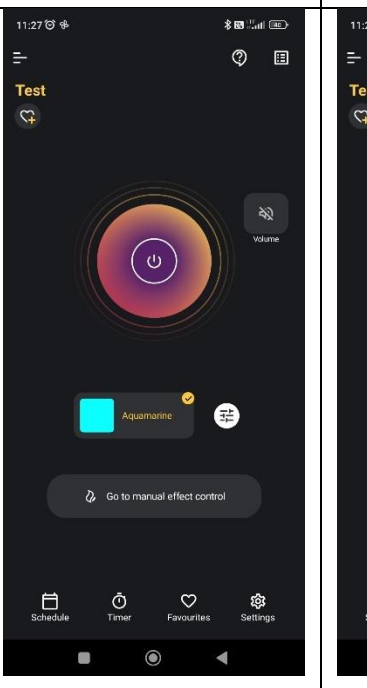
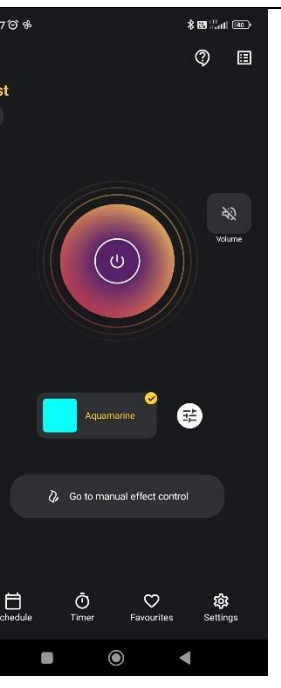
Starting the device	Warming the device	Working mode	Turning off
			
<p>Click on "ON / OFF button" to start the device</p>	<p>Device has to warm up for working mode.</p>	<p>Device will be ready to use in working mode after warming up.</p>	<p>Click on „ON / OFF button" to stop the device</p>

MENU (IN MANUAL MODE)





The screenshot shows a mobile application interface in manual mode. At the top, the status bar displays the time 11:28, signal strength, and battery level at 39%. The main screen features a central circular control with a power button icon. Below this are two panels: 'Moods' and 'Flame'. The 'Flame' panel shows 'Height' set to 'Low' and 'Colour' with a blue square. At the bottom, there are four icons: 'Schedule', 'Timer', 'Favourites', and 'Settings'. A volume control slider is visible on the right side of the screen.

Numbered callouts (1-12) point to the following elements:

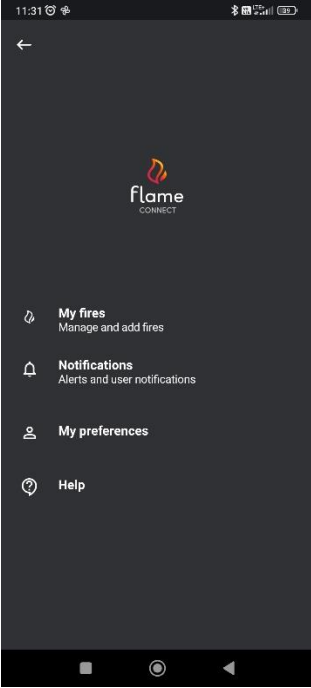
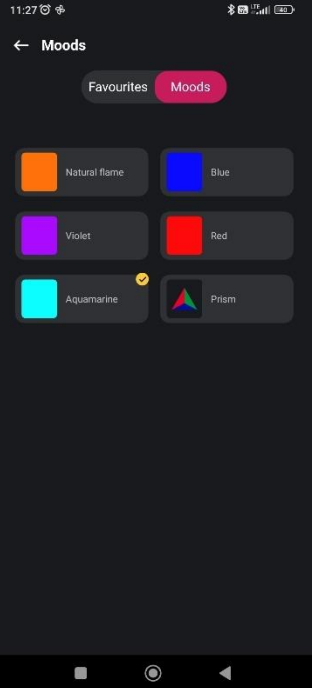
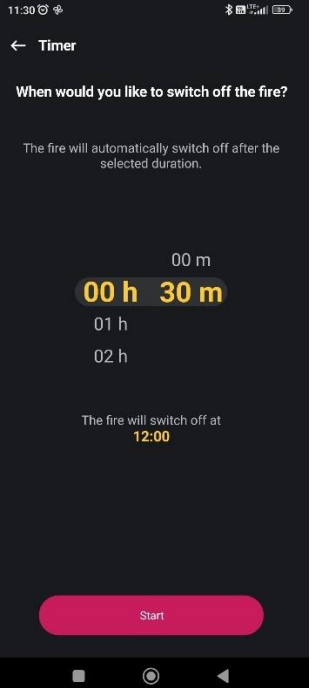
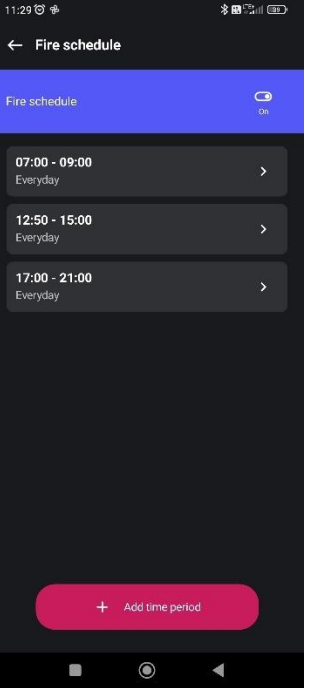
- 1: Main settings (hamburger menu icon)
- 2: Save settings (heart with plus icon)
- 3: Turn on / off device (power button icon)
- 4: Set mood (Moods panel)
- 5: Set timer (Timer icon)
- 6: Set schedule (Schedule icon)
- 7: Devices list (list icon)
- 8: Help (question mark icon)
- 9: Burning effect volume (Volume slider)
- 10: Flame effect (Flame panel)
- 11: Favourite settings (Favourites icon)
- 12: Device options (Settings icon)

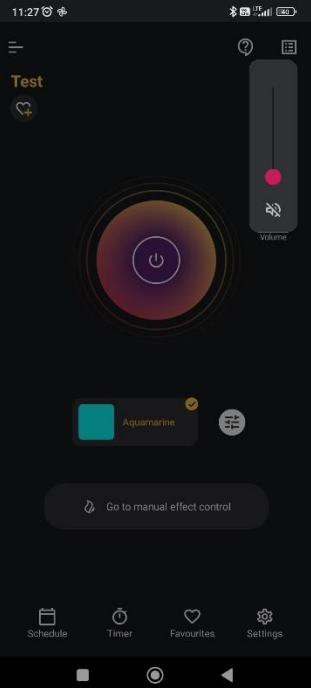
1. Main settings
2. Save settings
3. Turn on / off device
4. Set mood
5. Set timer
6. Set schedule
7. Devices list
8. Help
9. Burning effect volume
10. Flame effect
11. Favourite settings
12. Device options

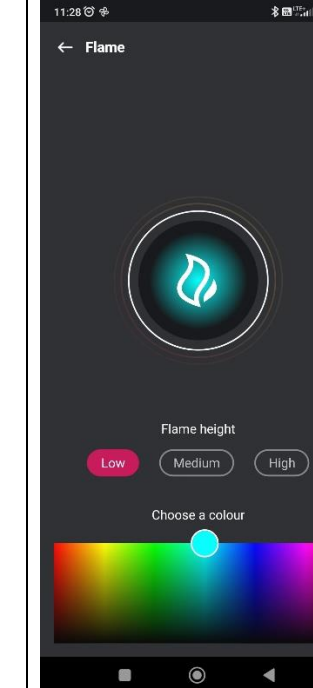
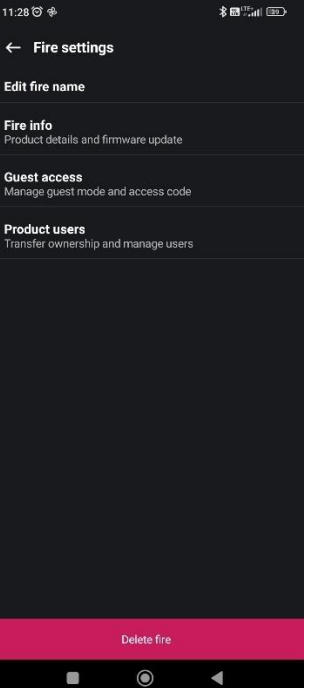
Main settings	Moods	Timer	Schedule
			
<p>Access to main information about devices and user.</p>	<p>Choose from favorite or set the new one</p>	<p>Set the time after device will stop working</p>	<p>Set the schedule of working mode or set manual control</p>

Volume	Devices list	Flame effect	Device options
			
<p>Set the "burning" volume</p>	<p>Add new or check the details of the available ones by clicking on  New user would be able to add the device in guest mode if it is already on other mobile device list.</p>	<p>Set the burning effect by choosing colour and</p>	<p>Current device information (see description below)</p>

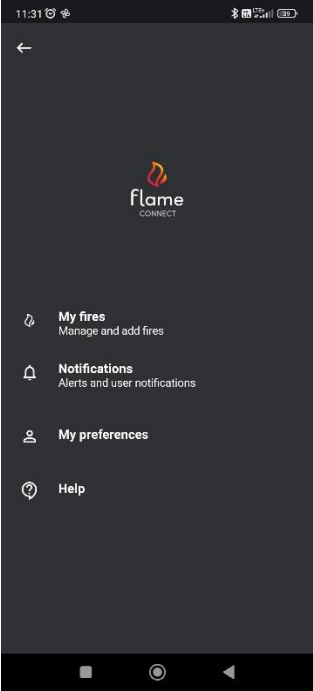
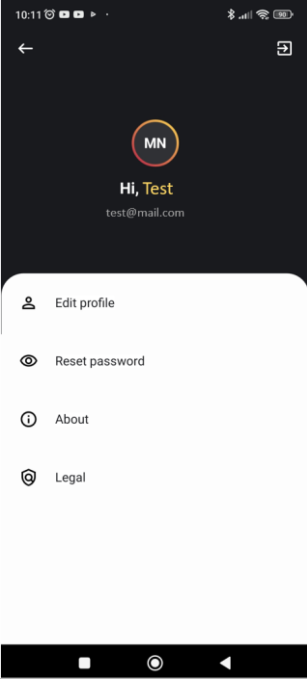

MY PREFERENCES

Main settings	My preferences		
			
<p>Go to main settings by clicking “main settings” icon on left upper corner</p>	<p>Go to “My preferences to edit profile, reset password and check info about app.</p>		

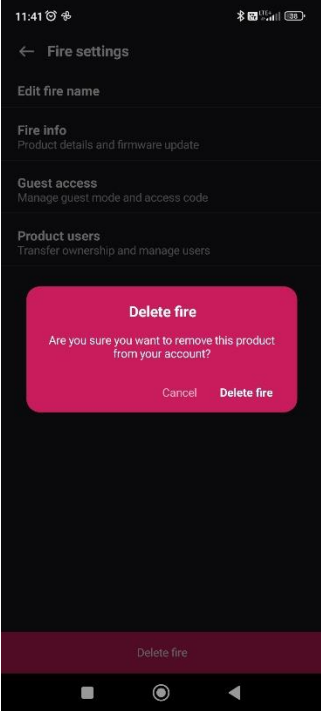
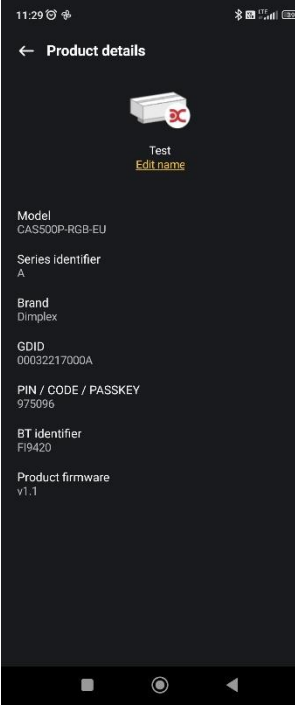
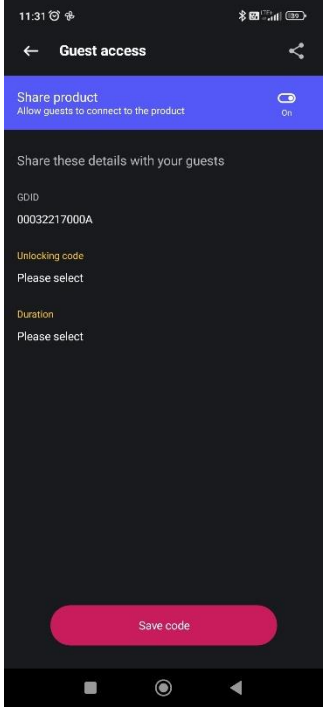
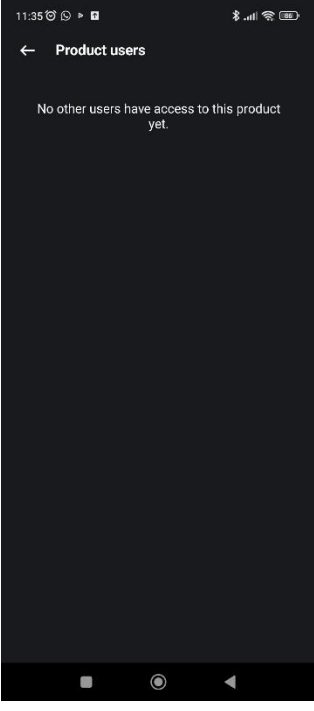
DEVICE OPTIONS

Delete fire	Fire info	Guest access	Product users
			
<p>You can delete the device from the mobile device by clicking on “Delete fire”.</p>	<p>Check the device information</p>	<p>Share the access to the device for other users as “guests”. Set the duration and access code.</p>	<p>List of product users</p>

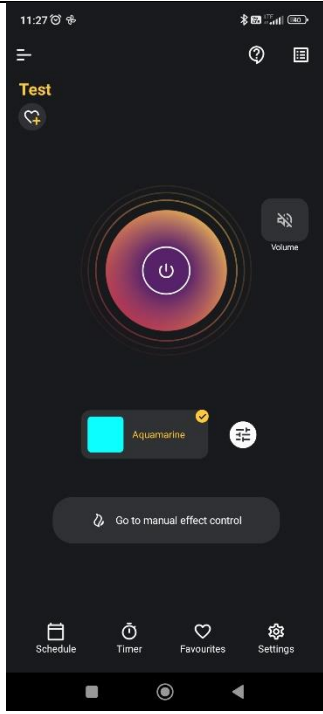
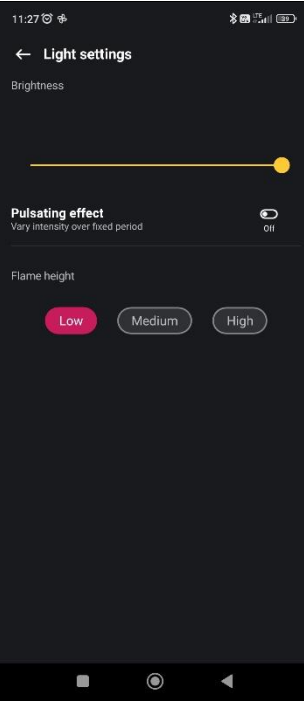
MOODS

Moods	Setting colour effect		
			
<p>Set the mood from the list or switch into manual</p>	<p>Click on  to go to color effects</p>		

NOZZLE INSERTS

Nozzle inserts have been supplied and fitted to the nozzle opening. These inserts are used to alter the profile of the flame effect. These inserts can be removed if a different flame profile is preferred. In addition to these inserts, inserts for blocking the flame in certain areas have also been supplied. To fit these inserts, remove the existing inserts that have been supplied and fitted to the product. Break the blocking inserts into the required length. Snap the inserts into the nozzle opening in the desired location. See (Fig 10) for further details.

Additional metal cover located on steam rail is dedicated to improve the steam effect. It is pre-assembled in factory nevertheless can be easily removed without any malfunctioning of the product. (fig. 11)

LOW WATER / REFILLING THE WATER TANKS

When the water tanks have emptied and the water level in the product is getting low, the product will flash its LEDs twice and beep twice. The product will operate for a further 15 minutes before beeping once and switching into low water mode. At this point, the product can either be switched into stand-by mode using the remote control or Bluetooth receiver or the product can be refilled with water. Refilling the product with water will cause the product to restart automatically.

To refill the tank, remove the top plate and remove the water tank from its position on top of the sump. Refill the water tank using filtered/decalcified water only. The tank can then be replaced on top of the sump. If the product was not switched into stand-by mode after experiencing low later, the product will restart automatically after about 20 seconds of refilling.

11. MAINTENANCE

GENERAL TIPS

Only use filtered / decalcified water in this appliance.

Always ensure that the appliance is sitting on a level surface.

If you intend not using the appliance for longer than a week, remove and empty the sump and water tank. Once installed, never move this appliance or lay on its back, without draining the water from sump.

CLEANING

WARNING: Always press Switch 'A' to the 'OFF' (0) position (Fig 8A) and disconnect from the power supply before cleaning the fire. We recommend cleaning the following components once every week, particularly in hard water areas: Sump, Nozzle, Tank cap and seal, Air filter

For general cleaning use a soft clean duster – never use abrasive cleaners.

To remove any accumulation of dust or fluff, the soft brush attachment of a vacuum cleaner should occasionally be used.

SUMP

1. Press Switch 'A' to the 'OFF' (0) position (Fig 8A)
2. Gently lift off the top plate and place it aside.
3. Remove the water tank from its position on top of the sump.
4. Disconnect the electrical connector to the transducers, located on the right side of the sump. (Fig 12).
5. There are two orange clips holding down the nozzle on the sump; one on the left and one on the right hand side of the nozzle. On the left side, press in the clip with one hand and with the other lift the nozzle out of the clip. Repeat this for the right side (Fig 13). The nozzle can now be lifted up and placed aside (Fig 14).
6. Gently lift up the sump (Fig 15), taking care to keep it level so as not to spill any water. Sit the sump in the sink.
7. Carefully empty the sump into the sink taking note that the transducer is held in place by a retaining clip.
8. Put a small amount of washing up liquid into the sump, and using a soft brush, gently clean all surfaces in the sump and gently clean the transducer including the cone and metal discs located in the top grooved surface.
9. When cleaned, thoroughly rinse the sump with clean water to remove all traces of washing up liquid.
10. Clean the nozzle with a soft brush and flush out thoroughly with water.
11. Reverse the above steps 1 – 6 to reassemble.

TRANSDUCER

The transducer is a consumable item and may need to be replaced through time, depending on its usage. Replacement transducers can be purchased from our your dealer. The transducer is fixed in the sump with a plastic clip. If you need to replace your transducer:

1. Follow the steps 1-5 in the CLEANING - Sump section under 'Maintenance' to gain access to the transducer.
2. Press the clip back and lift the transducer upwards out of its holder.
3. Place the new transducer into the sump, ensuring the its cable does not sit over the cone.
4. Reverse the above steps to reassemble the nozzle and sump.

AIR FILTER

1. Gently lift out the top plate and place it aside.
2. Gently slide the air filter upwards out of its plastic holder. (Fig 16)
3. Gently rinse with water in the sink and dry with fabric towel.
4. Replace the filter making sure that the coarse black filter is facing outwards.
5. Replace the top plate.

12. TROUBLESHOOTING

The product has been designed to highlight particular errors by flashing the on board LED lights. The lights will flash a number of times corresponding to the error that is occurring. Please see the table below for the explanation of the errors.

Symptom	Cause	Corrective Action
Product will not operate.	Electrical connection issue Product not switched on	Ensure product has working electrical connection. Ensure mains rocker switch on (Fig 8A)
Product will not operate. The LED top plate only operates.	Low water reading Product is not level	Refill the water tank(s) of the product. See "Filling the Water Tanks" above. Ensure the product is level by checking the on-board level
LEDs blink twice and product beeps twice	Product is approaching low water	Refill the water tank(s) of the product. See "Filling the Water Tanks" above.
Product will not operate. LEDs continuously blink twice on one side	Low water reading on side that is blinking	Refill the water tank(s) of the product. See "Filling the Water Tanks" above.
Product will not operate. LEDs continuously blink three times	Time from max level to min level is too short. Conflicting water level readings (min and max level being read at the same time.)	Ensure there are no leaks in the sump. Ensure that the floats are moving freely within the sump. Ensure the product is level.
Product will not operate. LEDs continuously blink four times	Fill time from min to max level has been exceeded	Refill the water tank(s) of the product. See "Filling the Water Tanks" above.
Product will not operate. LEDs continuously blink once every 8 seconds on one side	Overflow Detection on side that is blinking	Switch off the product and the water supply. Contact your dealer for assistance.
Little or No Mist Generation	Transducer not operating correctly Transducer is dirty Transducer is not sitting correctly in sump Fan is obstructed or blocked Nozzle is not on sump correctly Nozzle is blocked	Check operation of transducer Clean sump and transducer thoroughly Switch off product, take nozzle off sump and ensure transducer is fitted in sump correctly Remove air filter and clean. Ensure it is placed back in product correctly. Ensure Nozzle is sitting on sump correctly Clean sump, transducer and nozzle thoroughly
The flame effect has too much smoke.	Flame effect setting is too high	Turn down the flame effect. Give the product time to adjust to the new setting
Bluetooth Receiver stops working	Loose connection	Check connection to the receiver (Fig 5)
Remote Control stops working	Bluetooth range issue Bluetooth Receiver connection is loose Remote control batteries need replacing	Check positioning of Bluetooth Receiver. Ensure it is not encased in metal or concrete. Check connection to the receiver (Fig 5) Replace batteries with two new CR2032 batteries

13. ADDITIONAL INFORMATION

AFTER SALES SERVICE

Your product is guaranteed for two years from the date of purchase. Within this period, we undertake to repair or exchange this product free of charge (excluding transducer discs & subject to availability) provided it has been installed and operated in accordance with these instructions. Your rights under this guarantee are additional to your statutory rights, which in turn are not affected by this guarantee.

RECYCLING



At the end of the electrical products useful life it should not be disposed of with household waste. Please recycle where facilities exist. Check with your Local Authority or retailer for recycling advice in your area.

14. PATENT / PATENT APPLICATION

Products within the Optimyst range are protected by one or more of the following patents and patent applications:

Great Britain GB2460259B, GB2475794B, GB2418014, EP2029941, GB2436212, GB2402206B

United States US8413358, US8136276, US7967690, US8574086

Russia RU2434181

European EP2029941, EP2315976, EP1787063 (A1), EP2388527, EP2029941,

China CN101883953A, CN102105746A, CN101057105 (A), CN101438104

Australia AU2009248743A1, AU2007224634

Canada CA2725214, CA2579444, CA2645939

South Africa ZA2008/08702

Mexico MX2008011712

South Korea KR101364191

Japan JP5281417, JP5496291

Brazil BRP10708894

India 4122/KOLNP/2008

New Zealand NZ571900

15. APPENDIX

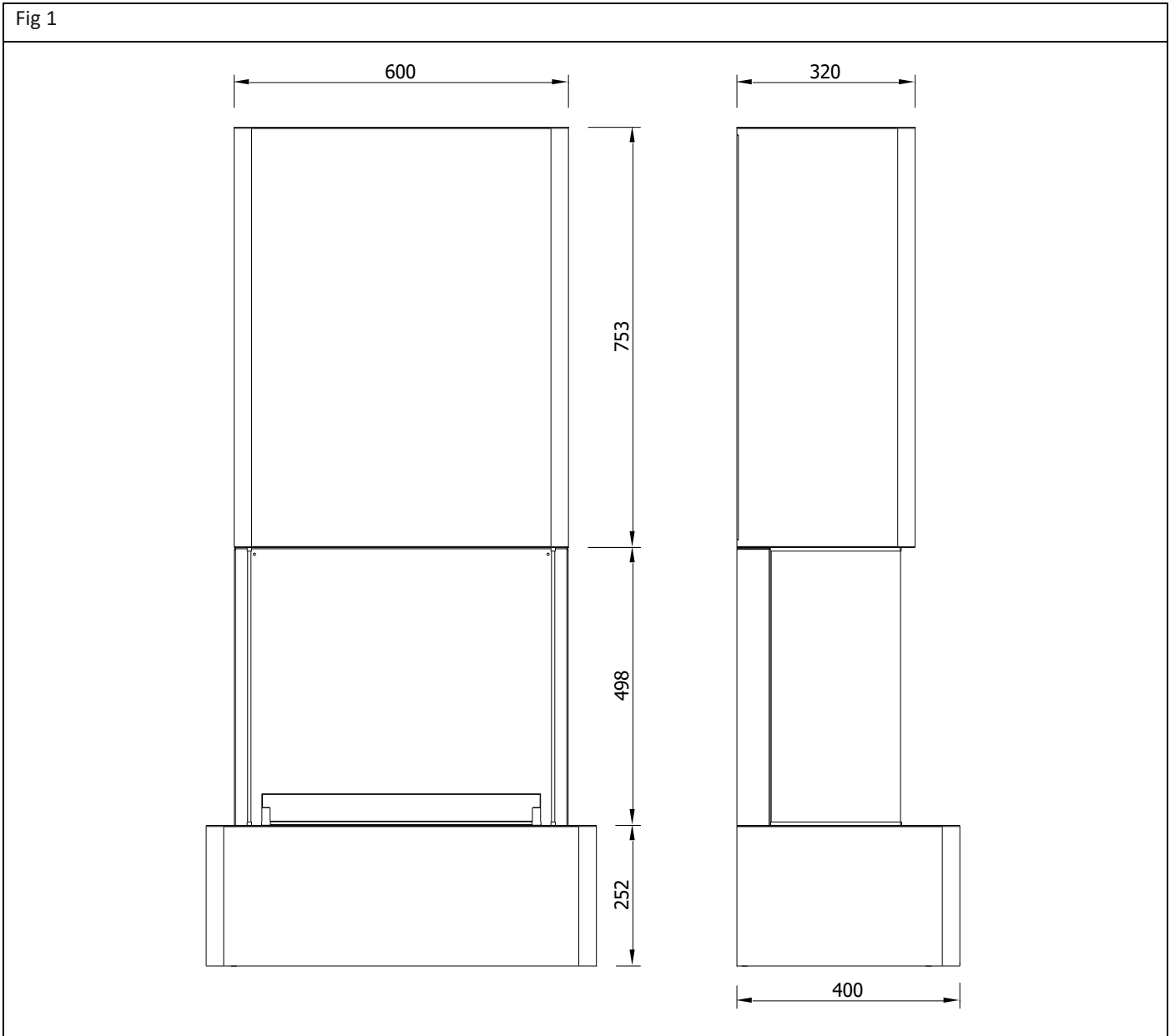

Fig 2

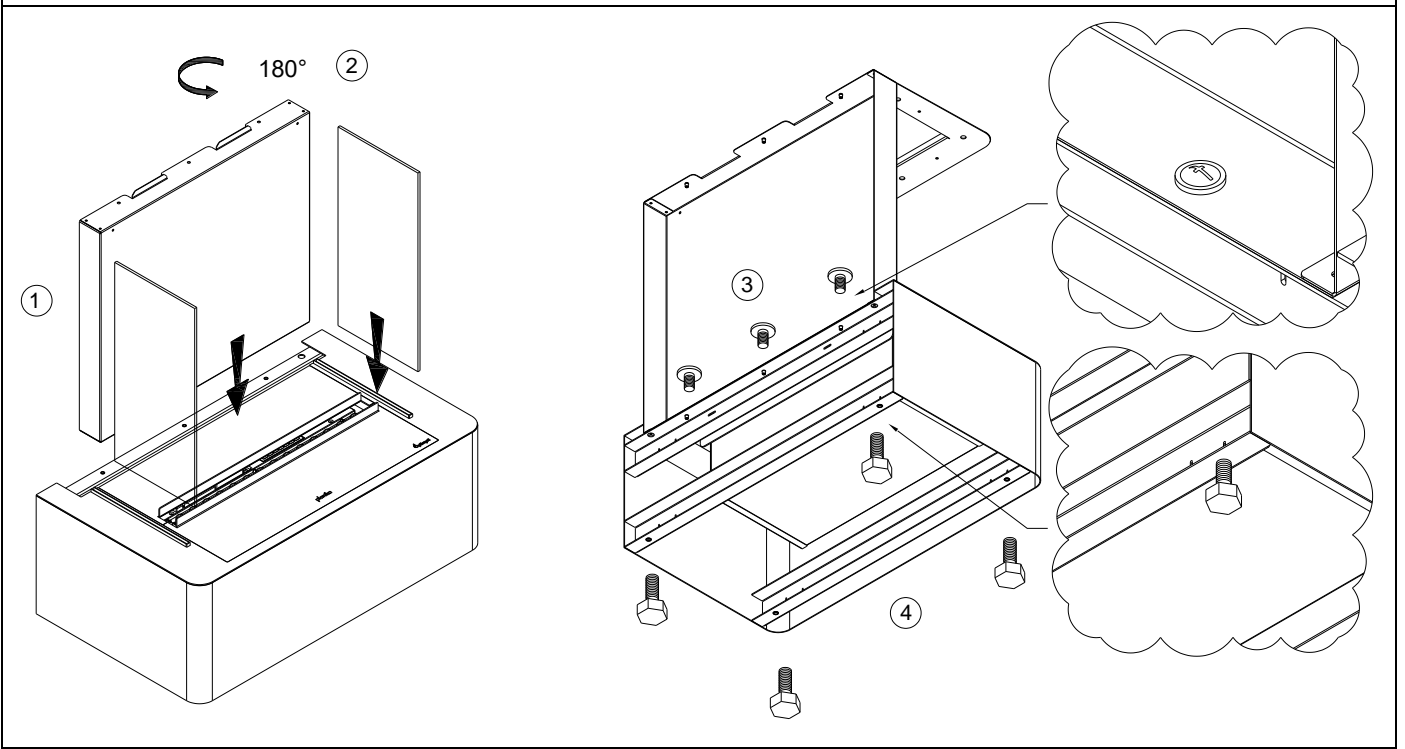

Fig 3

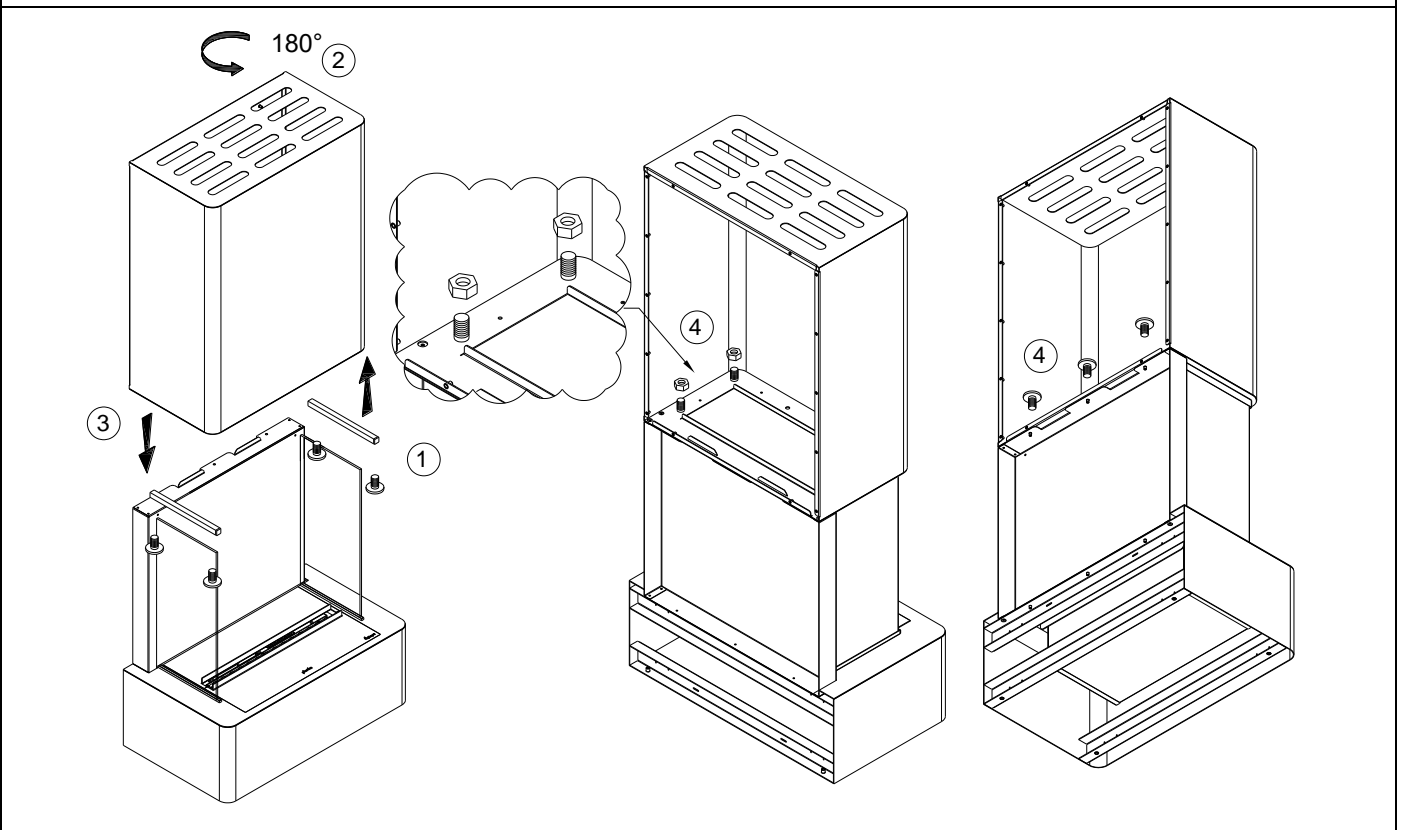

Fig 4

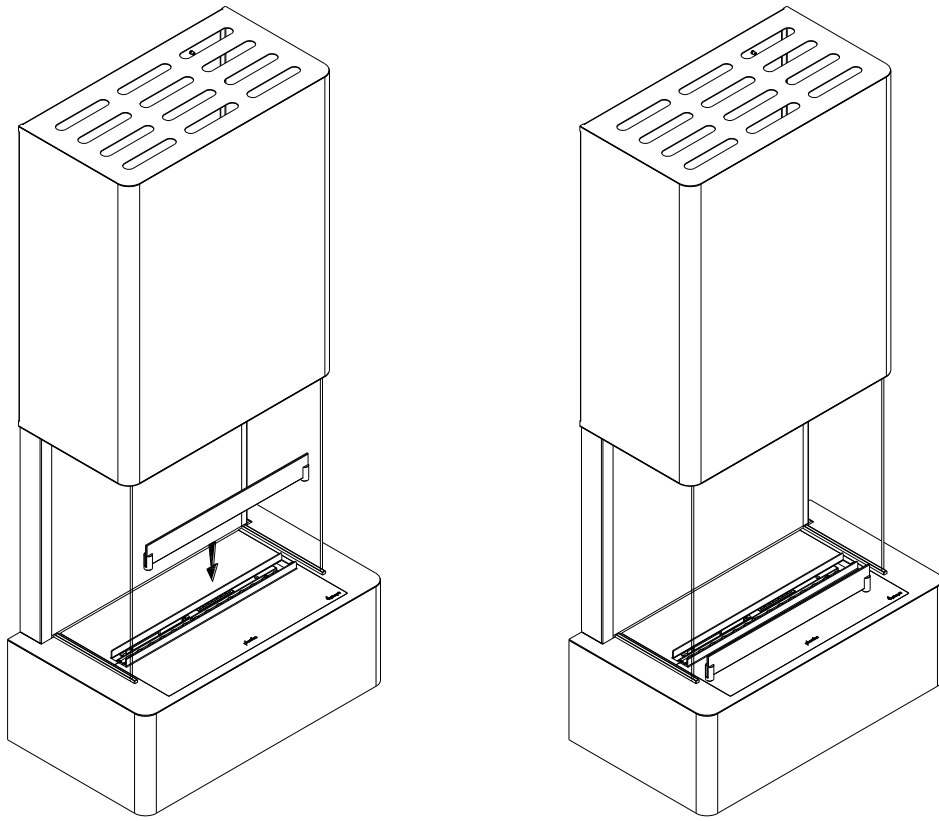

Fig 5

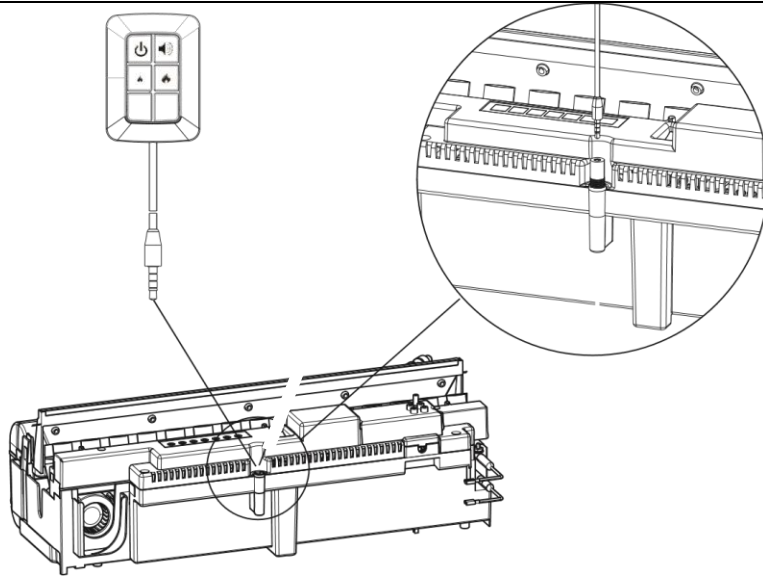

Fig 6

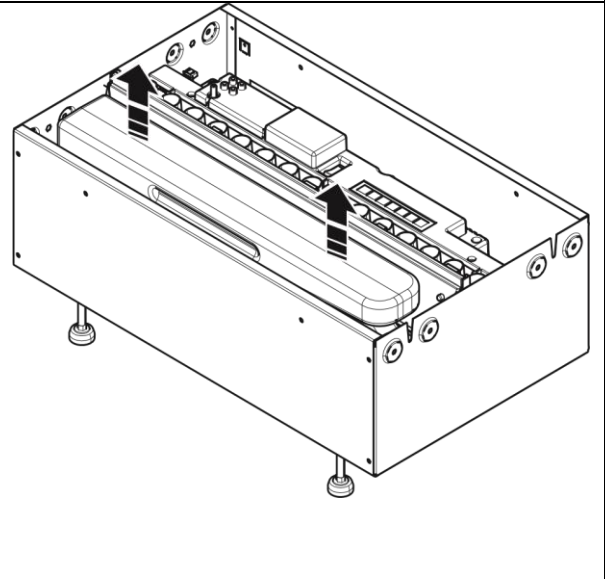

Fig 7

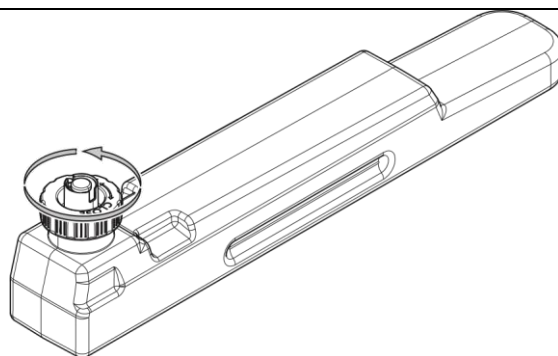

Fig 8

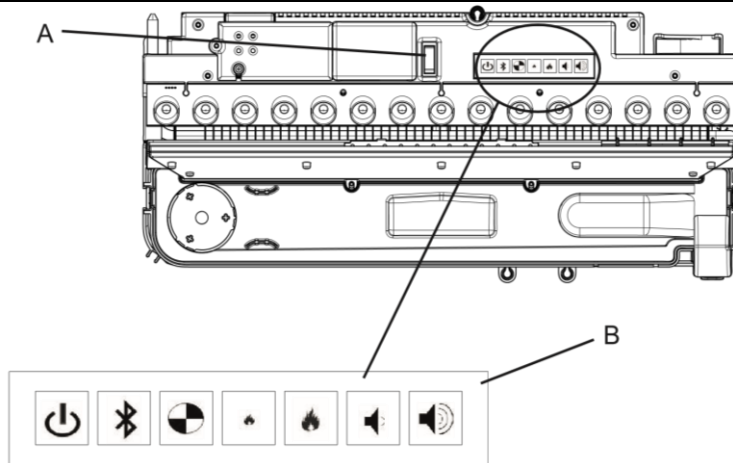

Fig 9

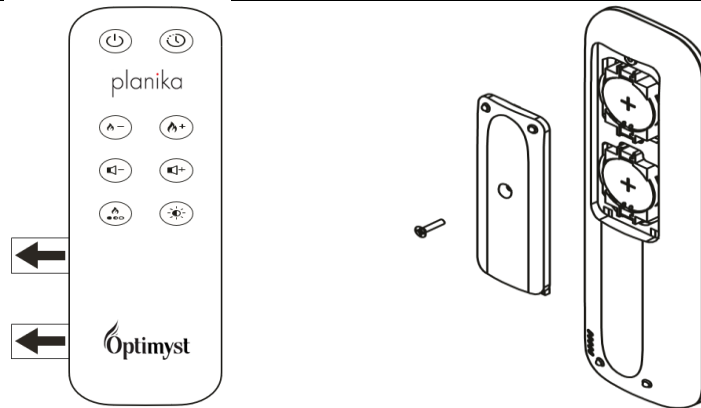

Fig 10

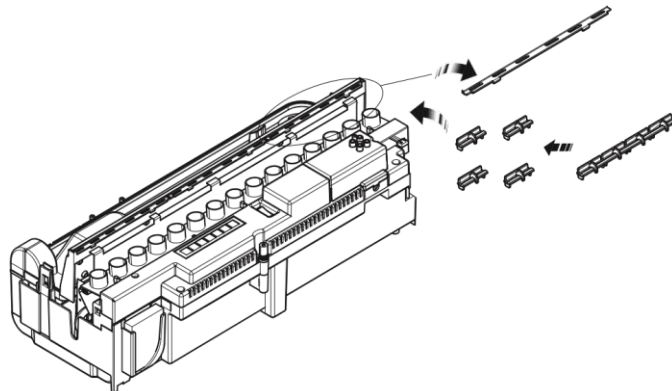

Fig 11

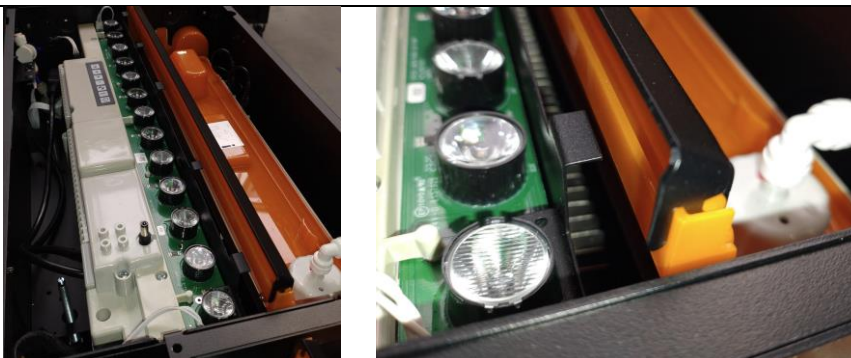

Fig 12

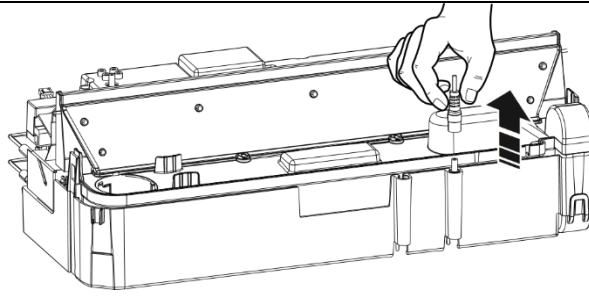

Fig 13

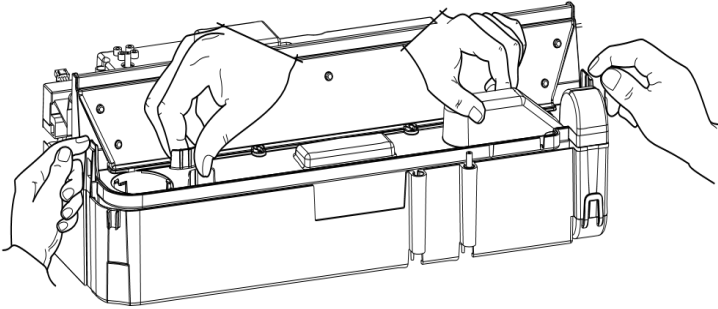

Fig 14

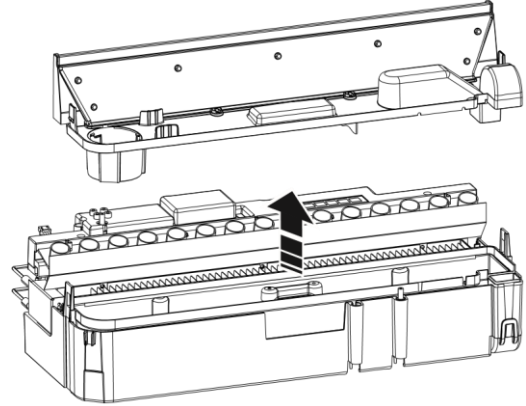

Fig 15

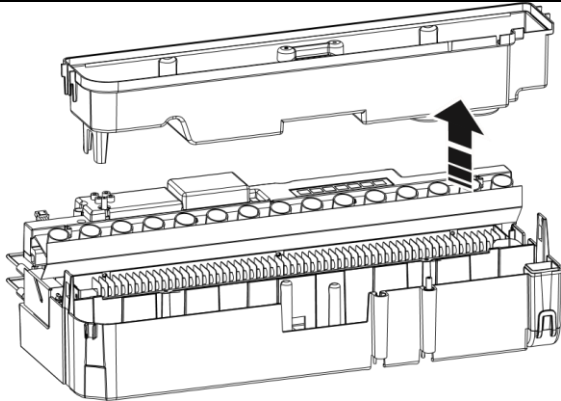

Fig 16

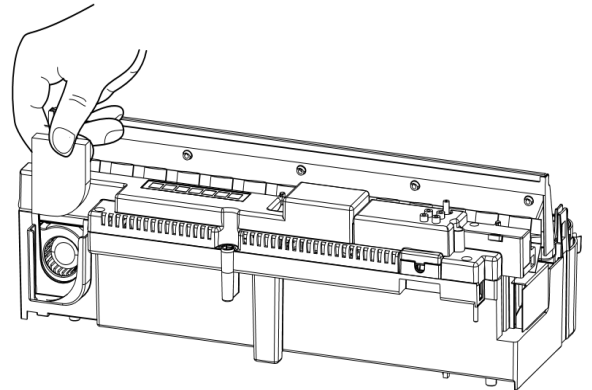

Fig 17

